

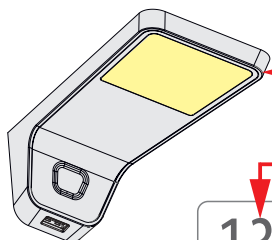

2022

LENA II USB

nazwa produktu/product name/produktname/название продукта



produkt Furnika / Furnika product / produkt Furnika / Фурниковый продукт









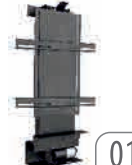
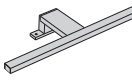
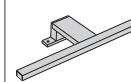
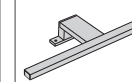
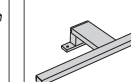
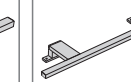
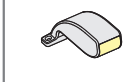
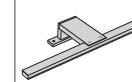
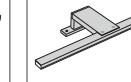
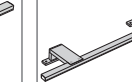
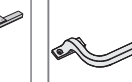

numer strony / page number / seitennummer / номер страницы

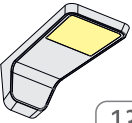
13

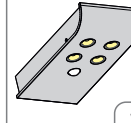
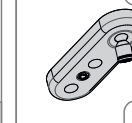
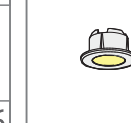
10.01.99.XY/USB

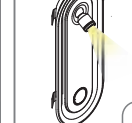
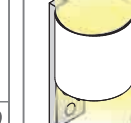
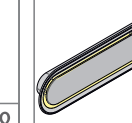
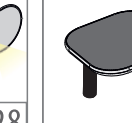

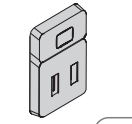

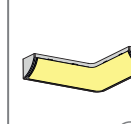
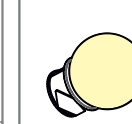
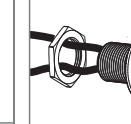
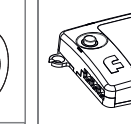
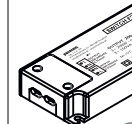
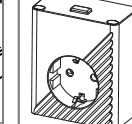
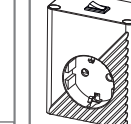
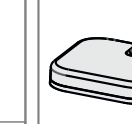
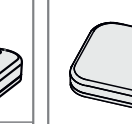
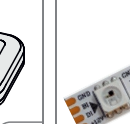





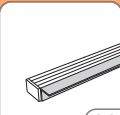
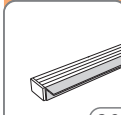
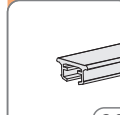
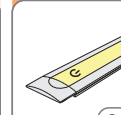
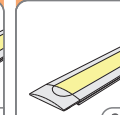
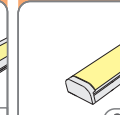
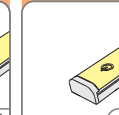
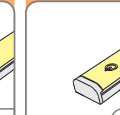
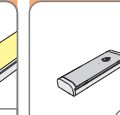
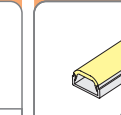
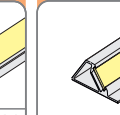
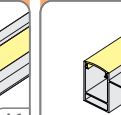
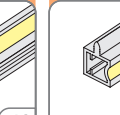
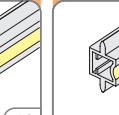
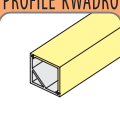
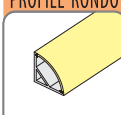
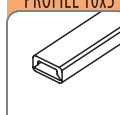
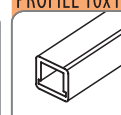
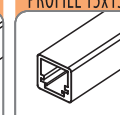
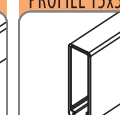
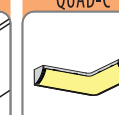
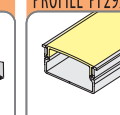
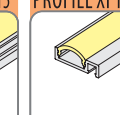
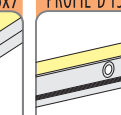
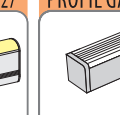
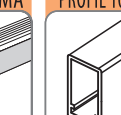
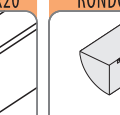
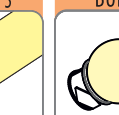

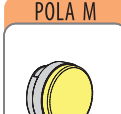
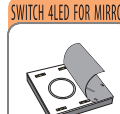
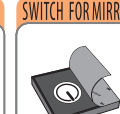
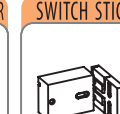
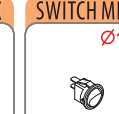
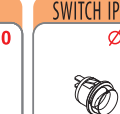
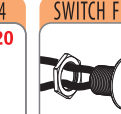
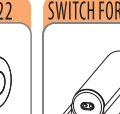
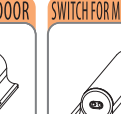
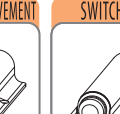
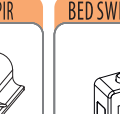
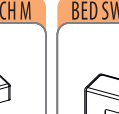
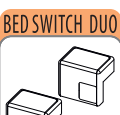
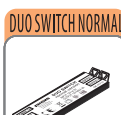
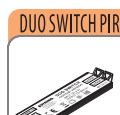
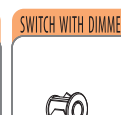
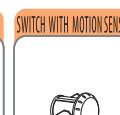
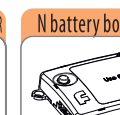
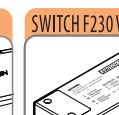
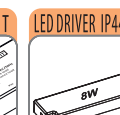
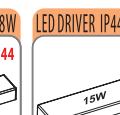
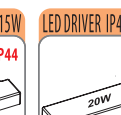
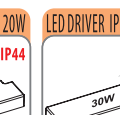
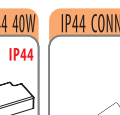
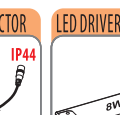
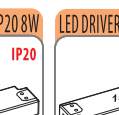

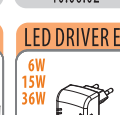
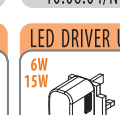
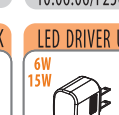

indeks/index/index/индекс

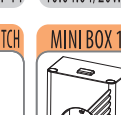
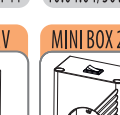
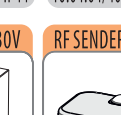
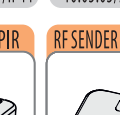
Nowe produkty / New products / Neue produkte / Новые продукты - 2021

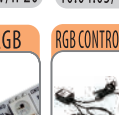
<p>TV LIFT 600</p>  <p>01</p> <p>10.10.10</p>	<p>ALA2 300/IP44</p>  <p>04</p> <p>10.01.94.XY/30</p>	<p>ALA2 400/IP44</p>  <p>04</p> <p>10.01.94.XY/40</p>	<p>ALA2 500/IP44</p>  <p>04</p> <p>10.01.94.XY/50</p>	<p>ALA2 600/IP44</p>  <p>04</p> <p>10.01.94.XY/60</p>	<p>ALA2 800/IP44</p>  <p>04</p> <p>10.01.94.XY/80</p>	<p>FILA</p>  <p>05</p> <p>10.01.131.XY</p>	<p>IDA 400</p>  <p>05</p> <p>10.01.105.XY/40</p>	<p>IDA 600</p>  <p>05</p> <p>10.01.105.XY/60</p>	<p>IDA 900</p>  <p>05</p> <p>10.01.105.XY/90</p>	<p>MIA</p>  <p>08</p> <p>10.01.130.XY</p>	<p>KITCHEN SET</p>  <p>09</p> <p>10.01.125.XY</p>
<p>LENA II</p>  <p>13</p> <p>10.01.99.XY</p>	<p>JUNO MOV</p>  <p>15</p> <p>10.01.106.XY/MOV</p>	<p>DOMINO</p>  <p>15</p> <p>10.01.102.XY</p>	<p>MAYA H/2m</p>  <p>16</p> <p>10.01.72.XY/H/2m</p>	<p>MINI LENS</p>  <p>17</p> <p>10.01.112.XY</p>	<p>SILKA USB</p>  <p>19</p> <p>10.01.115.XY/USB</p>	<p>SILKA COM</p>  <p>21</p> <p>10.01.115.XY/COM</p>	<p>MAYA COM</p>  <p>22</p> <p>10.01.134.XY</p>	<p>KINKIET</p>  <p>28</p> <p>10.01.153.XY</p>	<p>COMA COM</p>  <p>28</p> <p>10.01.144.XY</p>	<p>WIRELESS CHARGER</p>  <p>29</p> <p>10.05.13/FWC-1100</p>	<p>WIRELESS CHARGER POD</p>  <p>30</p> <p>10.05.13.X/FWC-1200</p>
<p>DOUBLE USB SWITCH</p>  <p>31</p> <p>10.05.25.X</p>	<p>USB-SWITCH</p>  <p>32</p> <p>10.05.18.X</p>	<p>QUAD-C</p>  <p>45</p> <p>10.01.133.XY</p>	<p>BULB</p>  <p>48</p> <p>10.01.143.XY</p>	<p>SWITCH FI 22</p>  <p>50</p> <p>10.05.14/12V</p>	<p>N battery box</p>  <p>55</p> <p>10.06.04/N</p>	<p>SWITCH F230V1T</p>  <p>56</p> <p>10.06.06/F230V</p>	<p>MINI BOX 12V</p>  <p>62</p> <p>20.05.16.X/6W</p>	<p>MINI BOX 230V</p>  <p>62</p> <p>20.05.17.X/230V</p>	<p>RF SENDER PIR</p>  <p>63</p> <p>10.04.20.X/PIR</p>	<p>RF SENDER TOUCH</p>  <p>63</p> <p>10.04.20.X/PIR</p>	<p>TAPE ARGB</p>  <p>64</p> <p>10.05.53/ARGB</p>

Spis obrazkowy / Picture index / Bild Index / содержание в картинках

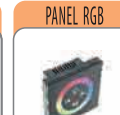
 TV LIFT 600 10.10.10	 BLUETOOTH 10.04.09.XY	 ANNA N 300/IP44 10.01.24.XY/30/N	 ANNA N 600/IP44 10.01.24.XY/60/N	 ELLI/IP44 10.01.70.XY	 ALA2 300/IP44 10.01.94.XY/30	 ALA2 400/IP44 10.01.94.XY/40	 ALA2 500/IP44 10.01.94.XY/50	 ALA2 600/IP44 10.01.94.XY/60	 ALA2 800/IP44 10.01.94.XY/80	 FILA 10.01.131.XY	 IDA 400 10.01.105.XY/40	 IDA 600 10.01.105.XY/60	 IDA 900 10.01.105.XY/90	 IDA 1100 10.01.105.XY/110
 BRITA 10.01.68.XY	 CELINA 10.01.107.XY	 STELLA 335 10.01.58.XY	 STELLA 635 10.01.58.XY/635	 GAMA 2 10.01.06.XY	 LINEA 10.01.90.XY	 ELIPSA 2/IP44 10.01.44.XY	 ELIPSA 1/IP44 10.01.45.XY	 MIA 10.01.130.XY	 ALICE 10.01.96.XY	 KITCHEN SET 10.01.125.XY	 NIKKA SWITCH 10.01.48.XY	 NIKKA MOV 10.01.50.XY	 NIKKA PIR 10.01.53.XY	 NIKKA DOOR 10.01.101.XY
 NEO2 10.01.52.XY	 SQUERE 2 10.01.20.XY	 SQUERE 2S 10.01.20.XY/S	 LENA 10.01.36.XY	 LENA MASTER 10.01.36.XY/MM	 LENA II 10.01.99.XY	 LENA II USB 10.01.99.XY/USB	 OVO 10.01.65.XY	 OVO DY 10.01.65.XY/DY	 OVO DYM 10.01.65.XY/DYM	 JUNO MOV 10.01.106.XY/MOV	 JUNO 10.01.106.XY	 DOMINO 10.01.102.XY	 MAYA 10.01.72.XY	 MAYA H/2m 10.01.72.XY/H/2m
 MAYA H 10.01.72.XY/H	 MAYA DY 10.01.72.XY/DY	 FLASH 10.01.30.XY	 POINT 10.01.22.XY	 BIG POINT 10.01.86.XY	 MINI LENS 10.01.112.XY	 MINI POINT 10.01.76.XY	 QUAD 10.01.77.XY	 QUAD 2 10.01.79.XY	 SPACE 10.01.78.XY	 SPACE 2 10.01.83.XY	 ADA 10.01.84.XY	 SILKA USB 10.01.115.XY/USB	 SILKA 10.01.115.XY	 SILKA COM 10.01.115.XY/COM
 MAYA COM 10.01.134.XY	 FLEXI Q 10.01.92.XY	 FLEXI H 10.01.104.XY/H	 FLEXI RH 10.01.104.XY/RH	 FLEXI R 10.01.91.XY	 ETA 10.01.39.XY	 BUTTERFLY 10.01.46.XY	 GABI Q 10.01.87.XY	 GABI Q-P 10.01.87.XY/Q/P	 GABI R 10.01.88.XY	 GABI R/USB 10.01.88.XY/USB	 GABI R/USB 10.01.88.XY/USB	 COMA 10.01.109.XY	 INLINE 10.01.111.XY	 INLINE-L 10.01.110.XY
 KINKIET 10.01.153.XY	 PEAK 10.01.114.XY	 COMA COM 10.01.144.XY	 WIRELESS CHARGER 10.05.13/FWC-1000	 WIRELESS CHARGER 10.05.13/FWC-1100	 WIRELESS CHARGER POD 10.05.13.X/FWC-1200	 USB /T CHARGER 10.05.13.X/T	 USB CHARGER 10.05.13.X	 USB /R CHARGER 10.05.13.X/R	 DOUBLE USB SWITCH 10.05.25.X	 USB-SWITCH 10.05.18.X	 LILI USB 10.01.74.XY	 LEG L 10.01.32.XY	 LEG P25 10.01.60.XY	 LEG P50 10.01.31.XY
 LEG HC 10.01.56.XY	 LEG H 10.01.57.XY	 STAR LED 10.01.85.XY	 NEON 8x15 FLEX 10.01.89.XY/G/8x15	 NEON 5x13 FLEX 10.01.89.XY/G/5x13	 TOUCH SWITCH FP 10.07.07.X	 ZETA 10.02.01.XY	 ZETA LINE 10.02.02.XY	 ZETA GLASLINE 10.02.03.XY	 ZETA S 2S 10.02.07.XY/2S	 ZETA S 3S 10.02.07.XY/3S	 ZETA 3S ZN 10.01.51.XY/3S	 PROFILE DFM 10.01.19.XY	 GAMA 2S 60mm 10.01.25.XY/2S	 GAMA 3S 60mm 10.01.25.XY/3S

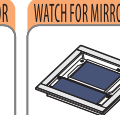
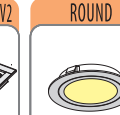
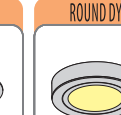
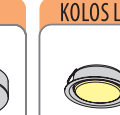
GAMA 2S 300mm  38 10.01.25.XY/2S/300	GAMA 3S 300mm  38 10.01.25.XY/3S/300	PROFIL TETA  38 10.01.05.XY	TAU SWITCH  39 10.01.28.XY/200/W	TAU  39 10.01.28.XY	OMEGA 200  39 10.01.26.XY/200	OMEGA SWITCH 200mm  40 10.01.26.XY/200W	OMEGA SWITCH MASTER 200mm  40 10.01.26.XY/200WM	OMEGA SWITCH  40 10.01.26.X/W	PROFILE OMEGA  41 10.01.26.XY	PROFILE LM  41 10.01.40.XY	PROFIL MIRROR  41 10.01.100.XY	PROFILE LAMBDA  42 10.01.27.XY	PROFILE AP  42 10.01.33.XY	PROFILE AP2H  42 10.01.33.XY/2H
PROFILE KWADRO  43 10.01.42.XY	PROFILE RONDO  43 10.01.41.XY	PROFILE 10x5  43 10.01.59.XY	PROFILE 10x10  44 10.01.34.XY	PROFILE 15x15  44 10.01.13.XY	PROFILE 15x50  44 10.01.14.XY	QUAD-C  45 10.01.133.XY	PROFILE PI 29x15  45 10.01.81.XY/29x15	PROFILE XI 16x7  45 10.01.82.XY	PROFIL D 15x27  46 10.01.66.XY/D	PROFIL GAMA  46 10.01.06.XY	PROFIL 10x20  46 10.01.124.XY	RONDO D  47 10.01.62.XY/D	RONDO S  47 10.01.61.XY/S	BULB  48 10.01.143.XY
POLA S  48 10.01.97.XY	POLA M  48 10.01.98.XY	SWITCH 4LED FOR MIRROR  49 10.05.09/4LED	SWITCH FOR CHIPBOARD  49 10.05.10	SWITCH FOR MIRROR  49 10.05.09	SWITCH STICK  49 10.04.15.X	SWITCH MINI  50 20.04.02.X/mini Ø15	SWITCH  50 20.04.02 Ø20	SWITCH IP44  50 20.04.02/IP44 Ø20	SWITCH FI 22  50 10.05.14/12V	SWITCH FOR DOOR  51 10.05.11/D	SWITCH FOR MOVEMENT  51 10.05.11/M.	SWITCH PIR  51 10.05.11/PIR	BED SWITCH M  52 10.05.16.X/M.	BED SWITCH L  52 10.05.16.X/L
BED SWITCH DUO  52 10.05.16.X/DUO	DUO SWITCH NORMAL  53 10.07.08/NORMAL	DUO SWITCH PIR  54 10.07.08/PIR/DOOR	SWITCH WITH DIMMER  55 10.05.06/CH	SWITCH WITH MOTION SENSOR  55 10.06.02	N battery box  55 10.06.04/N	SWITCH F230V1T  56 10.06.06/F230V	LED DRIVER IP44 8W  57 10.04.04/8W/IP44 IP44	LED DRIVER IP44 15W  57 10.04.04/15W/IP44 IP44	LED DRIVER IP44 20W  57 10.04.04/20W/IP44 IP44	LED DRIVER IP44 30W  58 10.04.04/30W/IP44 IP44	LED DRIVER IP44 40W  58 10.04.04/40W/IP44 IP44	IP44 CONNECTOR  58 10.05.05/2/IP44 IP44	LED DRIVER IP20 8W  59 10.04.03/8W/IP20 IP20	LED DRIVER IP20 15W  59 10.04.03/15W/IP20 IP20
LED DRIVER IP20 30W  59 10.04.03/30W/IP20 IP20	LED DRIVER IP20 40W  59 10.04.03/40W/IP20 IP20	LED DRIVER IP20 50W  59 10.04.03/50W/IP20 IP20	LED DRIVER IP20 60W  59 10.04.03/60W/IP20 IP20	LED DRIVER EU  60 10.04.01/6W 6W 15W 36W	LED DRIVER UK  60 10.04.01/15W/UK 6W 15W	LED DRIVER US  60 10.04.01/15W/USA 6W 15W	SOCKET SWITCH SWITCH  61 20.04.01/IP44F	SOCKET SWITCH SWITCH  61 20.04.01/F	MINI BOX 12V  62 20.05.16.X/6W	MINI BOX 230V  62 20.05.17.X/230V	RF-SENDER PIR  63 10.04.20.X/PIR	RF-SENDER TOUCH  63 10.04.20.X/PIR	TAPE ARGB  64 10.05.53/ARGB	RGB CONTROLLER IR2x  65 10.04.05/2RGB2K
RGB CONTROLLER IR2x  65 10.04.05/2RGB2K	RGB CONTROLLER IR  65 10.04.05	MINI RGB CONTROLLER  65 10.04.06	RF101 DIMMER SWITCH  66 10.04.08	PANEL RGB  66 10.04.07	LED DRIVER + DIMMER  66 10.07.05	WATCH FOR MIRROR  67 10.05.12.XY	WATCH FOR MIRROR V2  67 10.01.103.XY	ROUND  68 10.01.17.XY	ROUND Y  68 10.01.17.XY/DY	KOLOS LED  68 10.01.75.XY				

ANNA

← nazwa produktu/product name/produktname/название продукта

10.01.01.XY

↑
indeks/index/
index/индекс

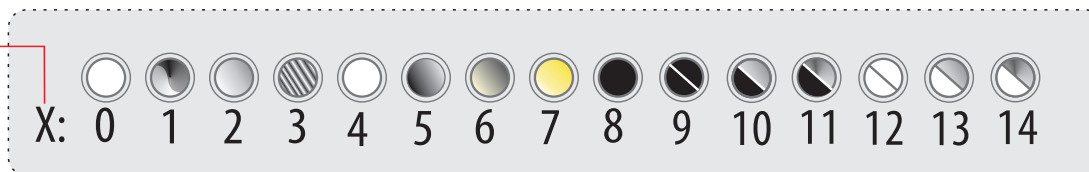

Kolor obudowy / HOUSING color / gehäusefarbe / цвет корпуса:

- transparentny / transparent / transparente /прозрачный 透明
- chrom / chrome / chrom /хром / 镀铬
- aluminium / aluminium / aluminium /алюминий 铝色
- ▨ inox /inox /inox /inox / 不锈钢拉丝
- biały / white / weiß / белый / 白色
- biały opal / white opal / opal weiss /белый опал / 乳白
- satyna / satin / nickel mat /атласа 镍拉丝
- złoto / gold / gold /золото / 金色
- czarny / black / schwarz / черный / 黑色
- czarny/czarny || black/black || schwarz/schwarz || черный/черный || 黑色 / 黑色
- czarny/aluminium || black/aluminium || schwarz/aluminium || черный/алюминий || 黑色 / 铝色
- czarny/chrom || black/chrome || schwarz/chrom || черный/хром || 黑色 / 镀铬
- biały/biały || white/white || weiß/weiß || белый/белый || 白色 / 白色
- biały/aluminium || white/aluminium || weiß/aluminium || белый/алюминий || 白色 / 铝色
- biały/chrom || white/chrome || weiß/chrom || белый/хром || 白色 / 镀铬

Kolor światła / light color / lichtfarbe / цвет света:

- biały zimny / cold white / kaltweiß /холодный белый / 正白光
- biały ciepły / warm white / warmweiß /теплый белый / 暖白光
- niebieski / blue/ blau /синий / 蓝光
- zielony / green / grün /зеленый / 绿光
- czerwony / red / rot /красный / 红光
- żółty / yellow / gelb /желтый / 黄光
- rgb RGB全彩
- biały 4200K/white 4200K/ weiß 4200K/белый 4200K / 自然白光
- różowy / pink/ pink / розовый



Zasilanie[V] / Power supply [V] / Spannung [V] / питание [V] 电源



Liczba diód LED/ moc [W] // LED pcs. / Power [W] // Anzahl der LEDs [st.] / Leistung [W] // количество LED диодов / мощность [W] LED数量及功率



Długość kabla [m]/ wtyczka LED mini // Cable length [m] / Mini-LED Plug // Kabellänge [m] / Mini-LED Stecker // длина кабеля [m]/ LED灯用电源线长度及类型



Moc transformatora [W] / Transformer power [W] / Netztrafo Leistung [W] / мощность трансформатора [W] 变压器功率



Moc dopuszczalna obciążenia wyłącznika [W] / Switch max. power [W] / Endschalter max Belastung [W] / максимально допустимая мощность [W] 开关及最大负载功率



Długość kabla [m] / wtyczka sieciowa 230V // Cable length [m]/230V AC Plug //Kabellänge [m] /230V AC Plug // длина кабеля [m] / 230V AC вилку 230v交流用电源线

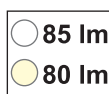

Strumień świetlny / luminous flux / Lichtstrom / мощность потока 光通量



Zarejestrowany wzór wspólnotowy /Registered Community design /Gemeinschaftsgeschmacksmusters /зарегистрировано дизайн Сообщества



RoHS



Produkty spełniają wymagania wg zastosowania/
The products meet the requirements for use/
Die Produkte erfüllen die Anforderungen für den Einsatz/
Изделия соответствуют требованиям для использования
产品满足的防水防尘等级要求

PL - Katalog zawiera zdjęcia i opisy które stanowią informację handlową i nie stanowią oferty handlowej w rozumieniu prawa.

EN - The catalog contain photos and descriptions which constitute commercial information and they do not constitute a commercial offer within the law meaning.

DE - Änderungen in Programm, Material, Ausführungen, Farben, Abmessungen und drucktechnisch bedingen Farbabweichungen bleiben vorbehalten

RU - Каталог содержит фотографии, технические описания и др. характеристики продуктов. В свете права каталог не является коммерческим предложением

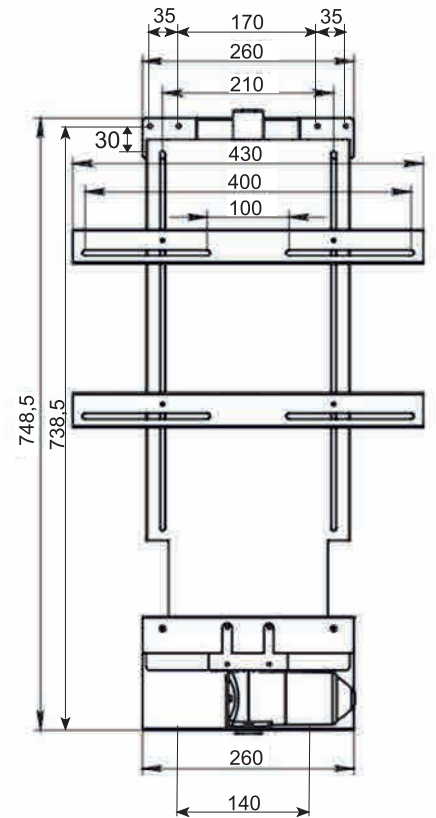
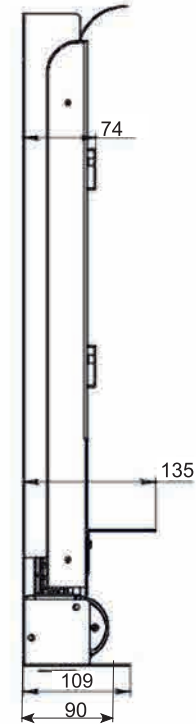

RF 433MHz | CE | IP20 | | IN : 100-240VAC; MAX 52,2W | for TV: 42" | MAX Load: 60kg

BLUETOOTH

10.04.09.X X: 0 8



Match the light to your mood with **Furnika LED**.



iOS
Android



- 12V_{DC}
- 0,1m
- MAX 3A
- Bluetooth max. 10m
- EMC

MANUAL - BLUETOOTH

1 POWER 12 VDC

2 To connect the RGB LED LIGHT use plugs 1 and 2

3 To connect the WARM WHITE / COLD WHITE LIGHT use plugs 1 and 3

4 To connect the SINGLE COLOUR LIGHT use plug 3

1 white plug
2 black plug
3 black plug

CLIP - ELLI/ANNA/AGNES/ALA

10.01.70.X/CLIP X: 1 ● 2 ○

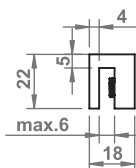
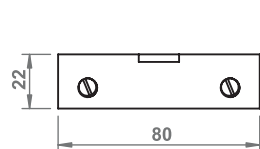
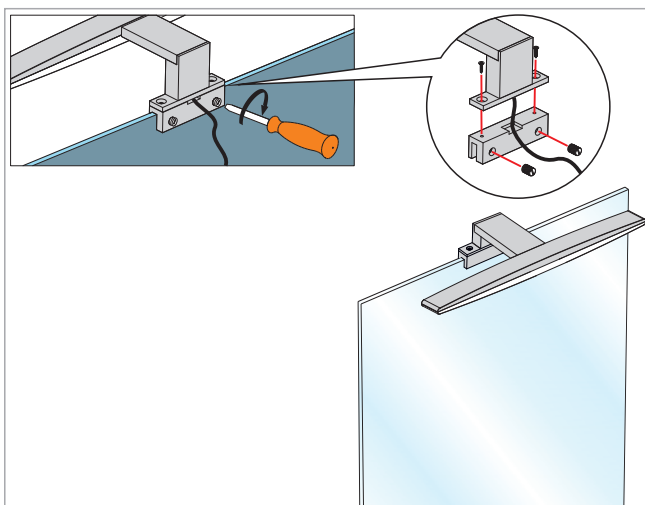

ANNA N /IP44

10.01.24.XY/30/N X: 1 ● 2 ○ Y: 1 ○ 2 ●

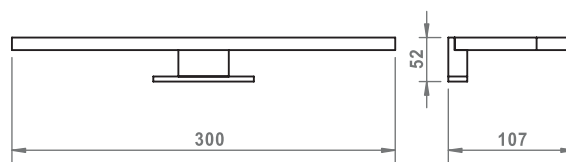
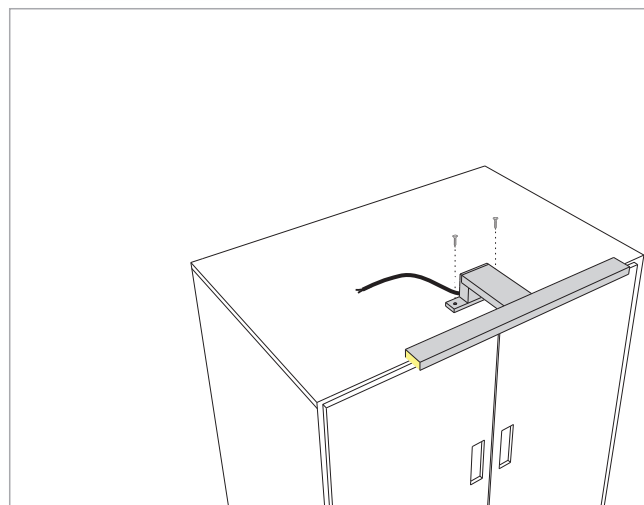

ANNA N 60 /IP44

10.01.24.XY/60/N X: 1 ● 2 ○ Y: 1 ○ 2 ●

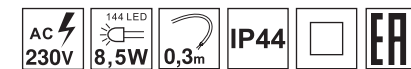
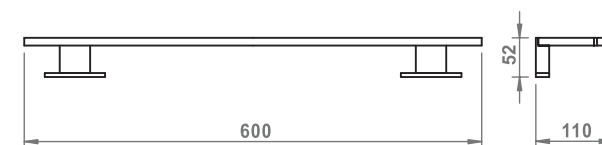
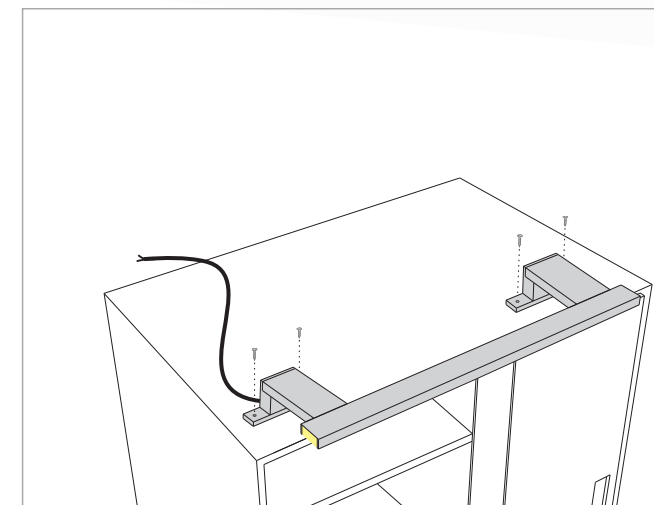

ELLI /IP44

10.01.70.XY X: 1 ● 2 ○ Y: 1 ○ 8 ○

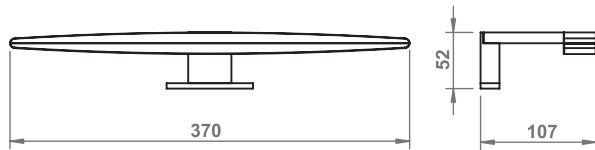
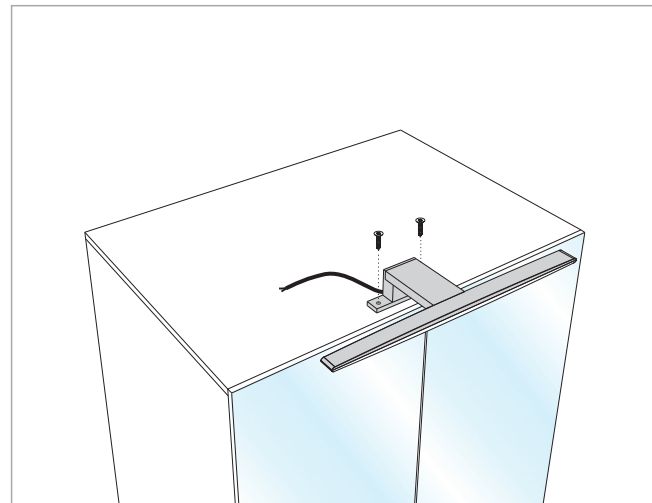

ALA2 300/400/500/600 IP44

X: 1 ● 2 ○ 8 ● Y: 1 ○ 2 ○ 8 ○

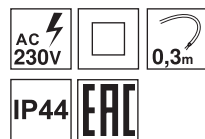
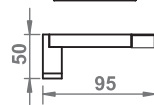
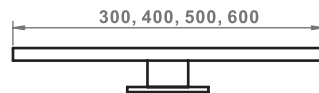
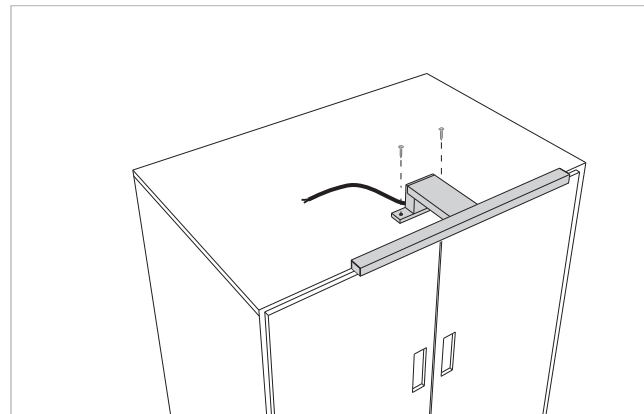

ALA2 300/IP44
10.01.94.XY/30 **2,5W**

ALA2 400/IP44
10.01.94.XY/40 **3,3W**

ALA2 500/IP44
10.01.94.XY/50 **4,2W**

ALA2 600/IP44
10.01.94.XY/60 **5,0W**

ALA2 800 IP44

10.01.94.XY/80 X: 1 ● 2 ○ 8 ● Y: 1 ○ 2 ○ 8 ○

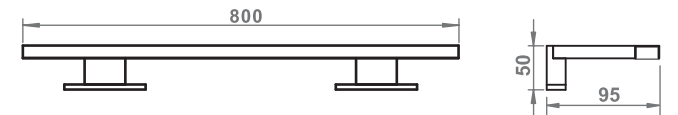
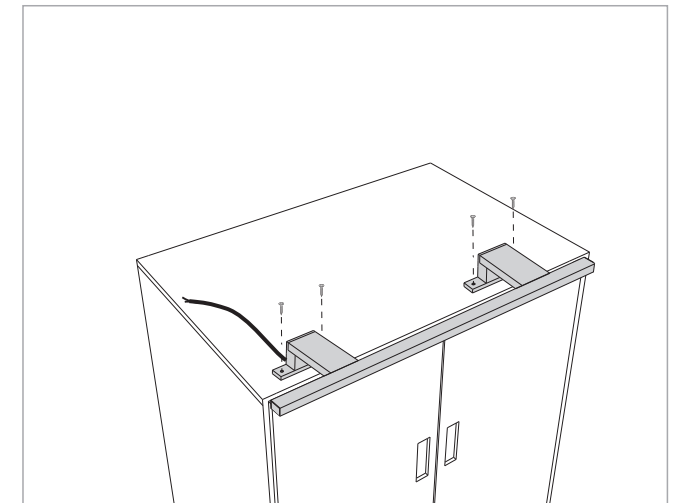

FILA

10.01.131.XY X: 1 ● 8 ● Y: 8 ○

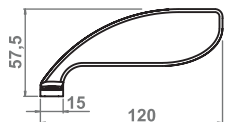
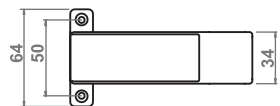
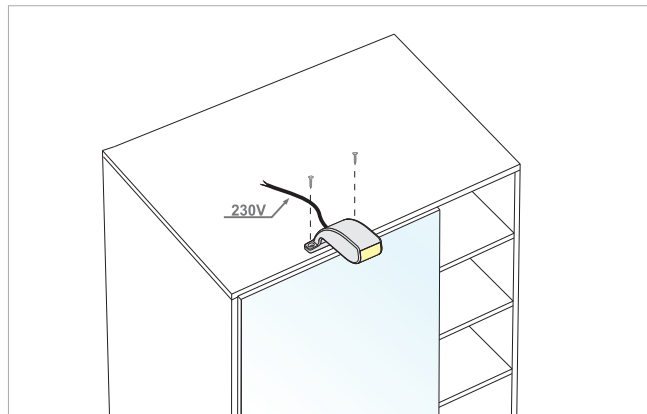

IDA 400 || IDA 600

10.01.105.XY X: 1 ● 2 ● Y: 1 ○ 2 ○

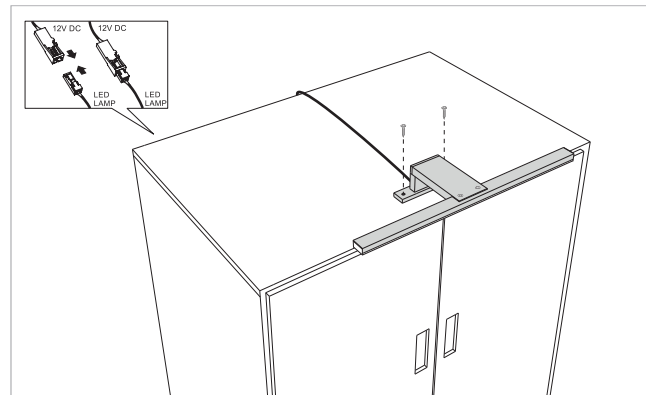

IDA 400
10.01.105.XY/40

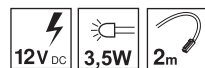
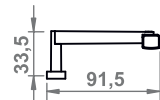
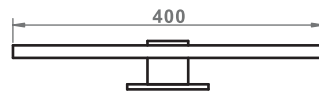

IDA 600
10.01.105.XY/60

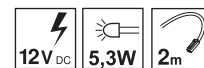
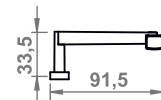
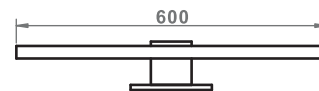

IDA 900

10.01.105.XY/90 X: 1 ● 2 ● Y: 1 ○ 2 ○

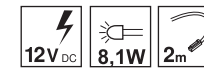
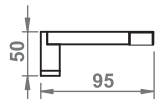
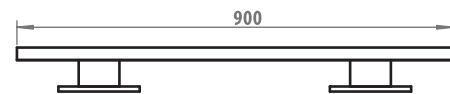
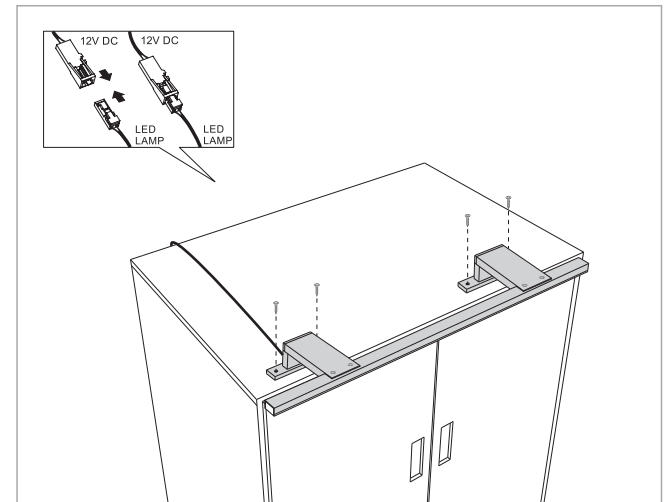

IDA 1100

10.01.105.XY X: 1 ● 2 ○ Y: 1 ○ 2 ○

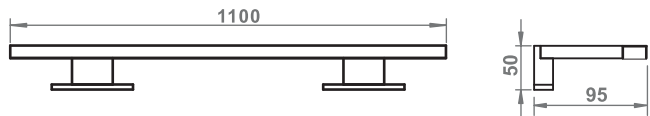
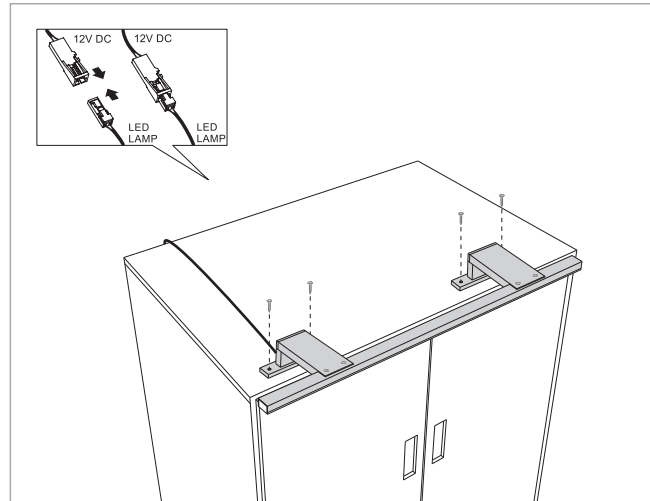

BRITA

10.01.68.XY X: 2 ○ Y: 1 ○ 2 ○ 3 ○ 4 ● 5 ● 6 ● 7 ●

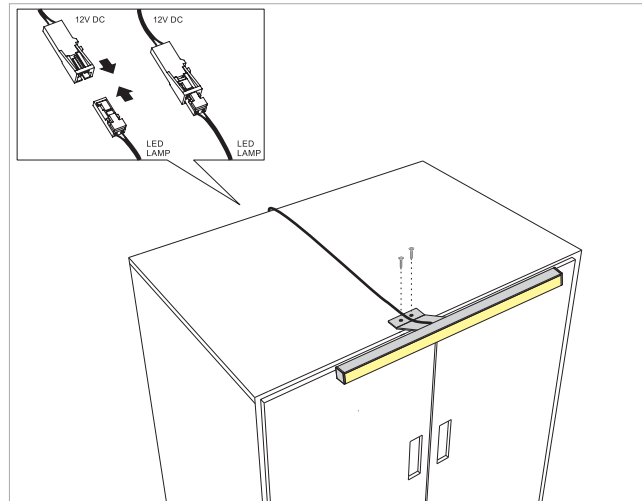
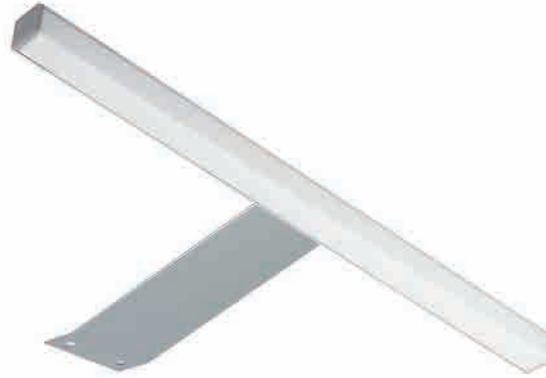

CELINA

10.01.107.XY X: 4 ○ 8 ● Y: 1 ○ 2 ○ 8 ○

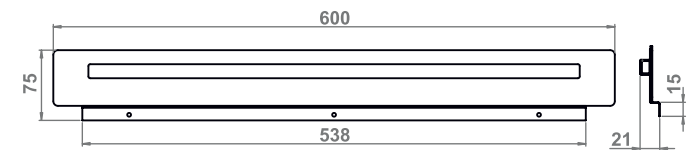
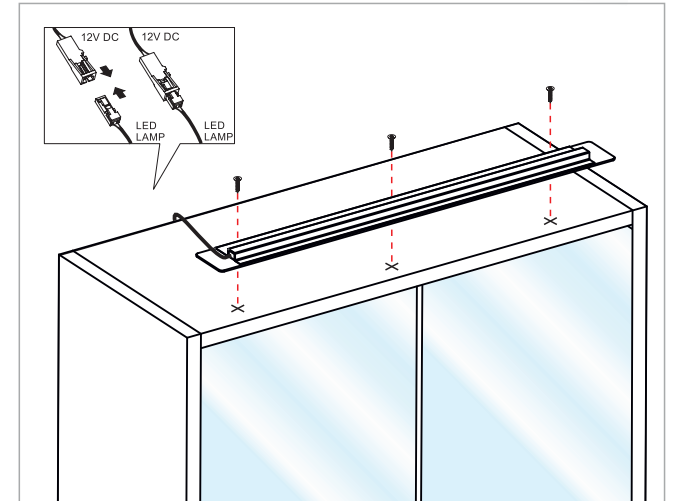

STELLA

10.01.58.XY X: 2 4 8 Y: 1 2 8

LINEA

10.01.90.XY X: 2 Y: 1 2 8

GAMA 2

10.01.06.XY/W X: 2 Y: 1 2 8

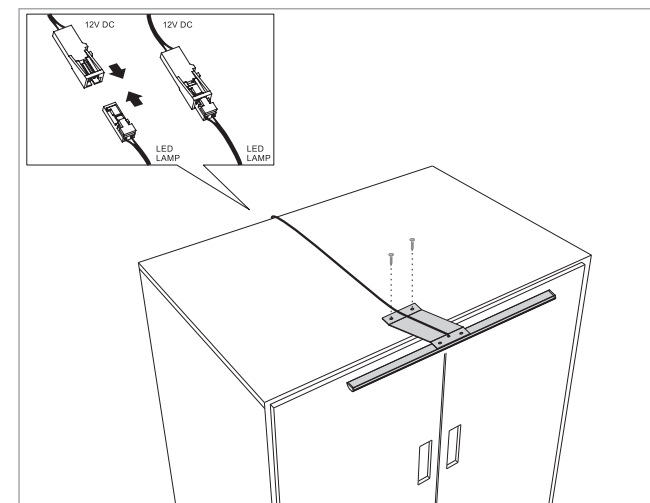
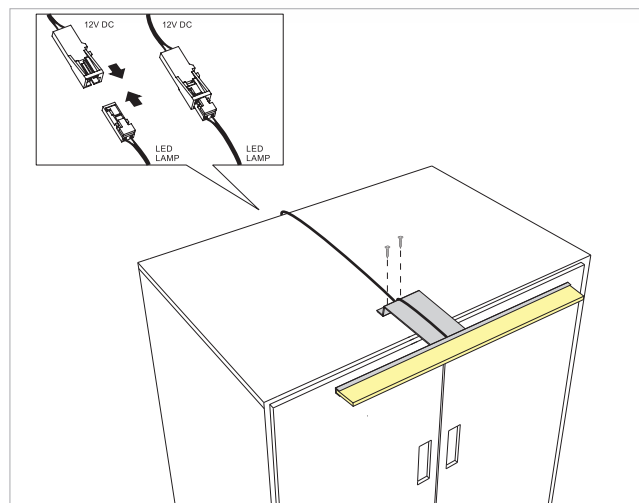
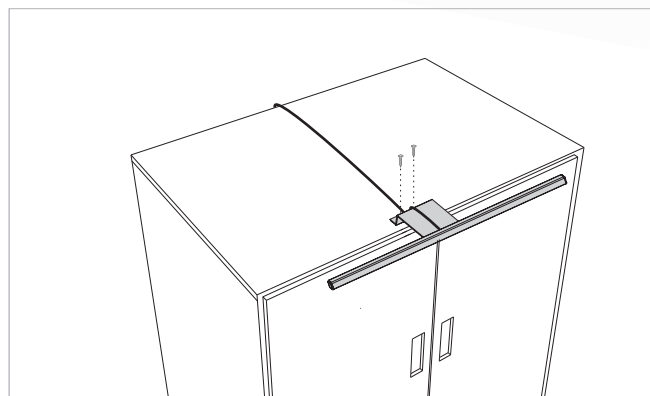

STELLA 635
10.01.58.XY/635

STELLA
10.01.58.XY

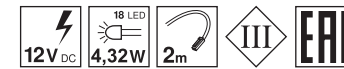
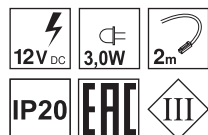
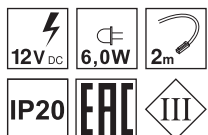
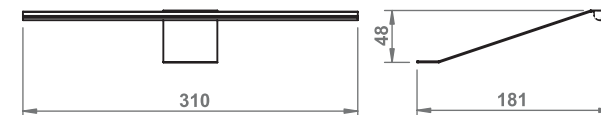
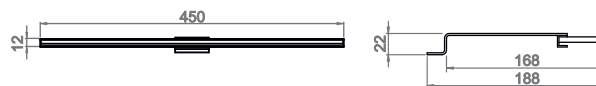
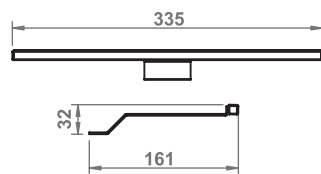
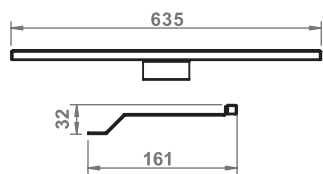

ELIPSA 1 /IP44

10.01.45.XY X: 1 ● 2 ○ 4 ○ 8 ● Y: 1 ○ 2 ○ 8 ○



ELIPSA 2 /IP44
10.01.44.XY

MIA

10.01.130.XY X: 1 ● 8 ● Y: 8 ○



ALICE

10.01.96.XY X: 2 ○ Y: 1 ○ 2 ○ 8 ○

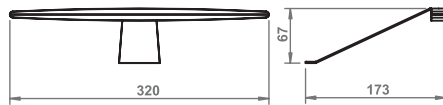
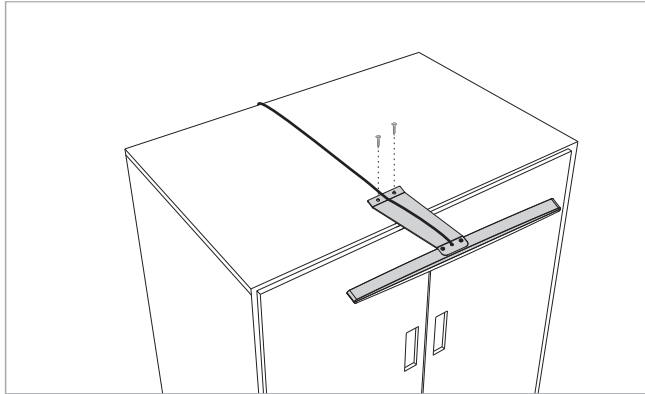

ELIPSA 1
10.01.45.XY

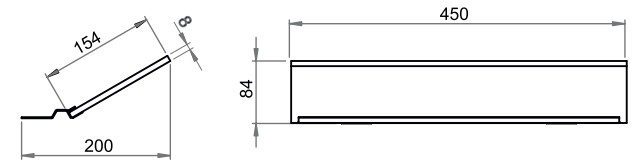
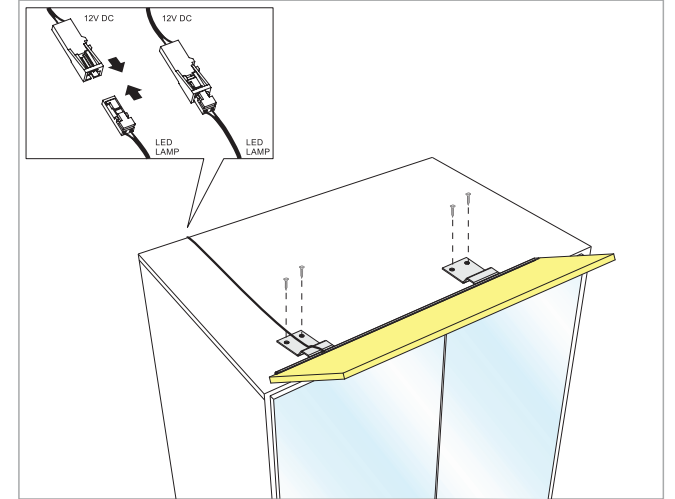
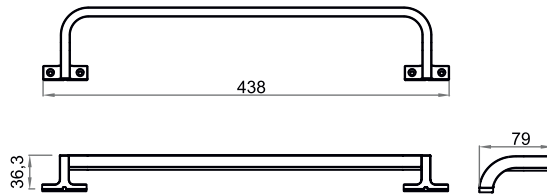
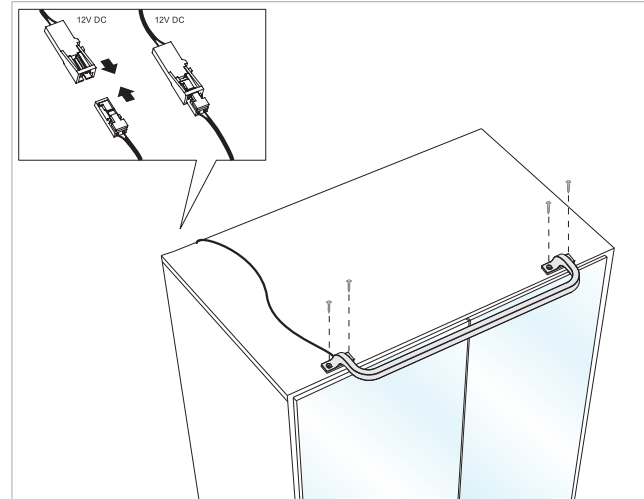



Profil Set
10.01.125.XY/Lmm

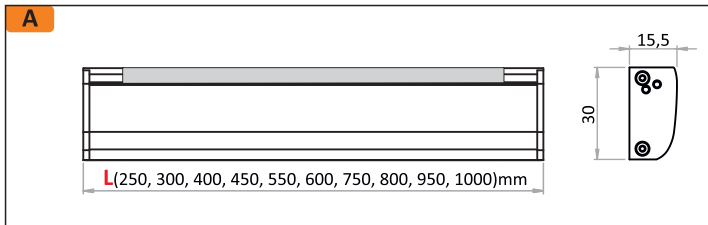
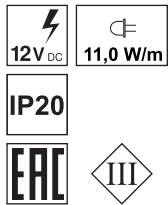

Movement
10.01.125.XY/MOV

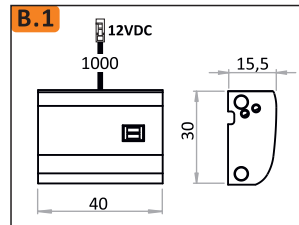

Movement+USB
10.01.125.XY/MOV/USB

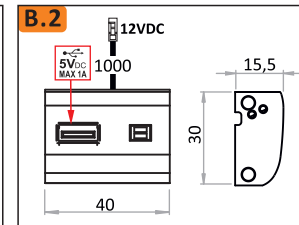

Connector 5
Left with cable
10.01.125.XY/CON5

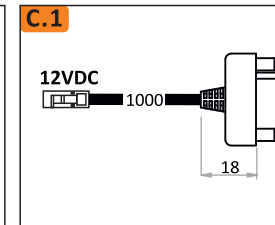

Connector 6
Right with cable
10.01.125.XY/CON6

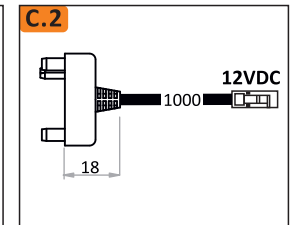

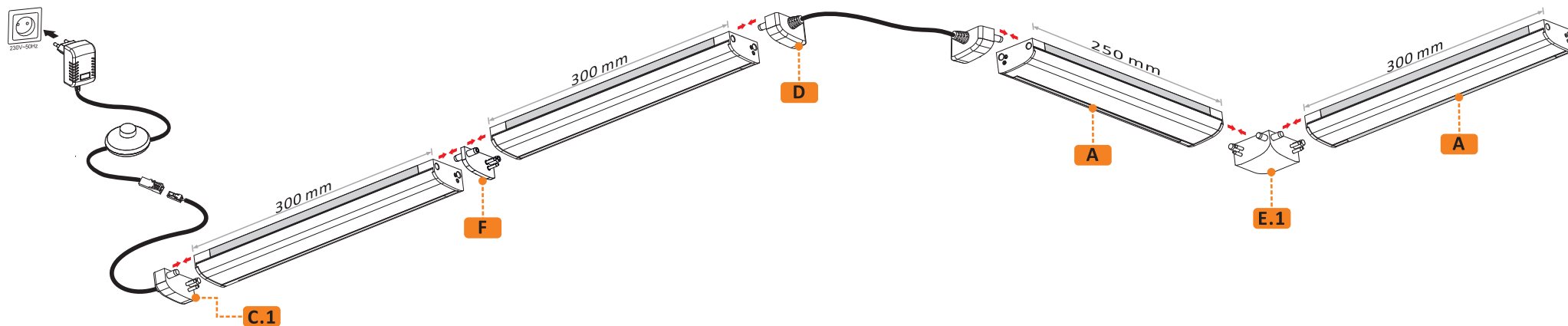
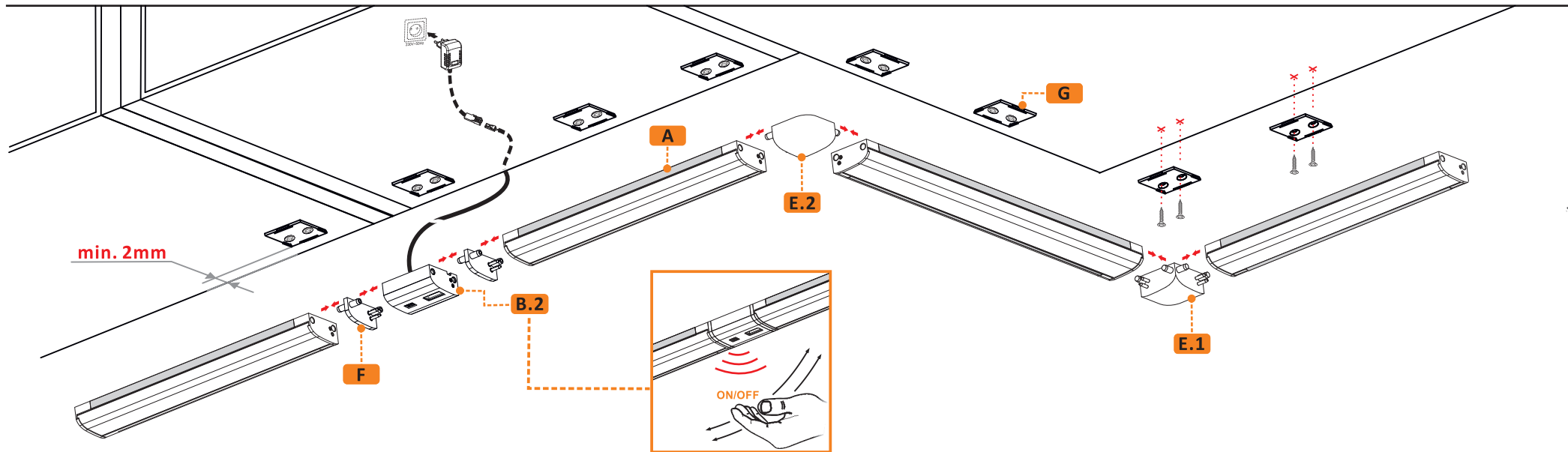

Connector 3 - 2m
10.01.125.XY/CON3/2m

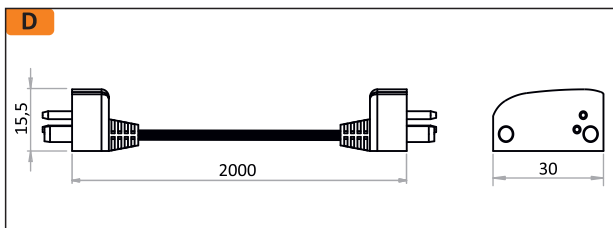

Left Connector
10.01.125.XY/LC

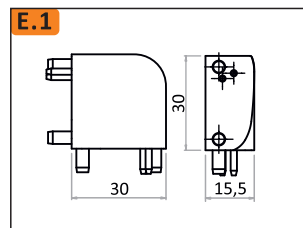

Right Connector
10.01.125.XY/RC

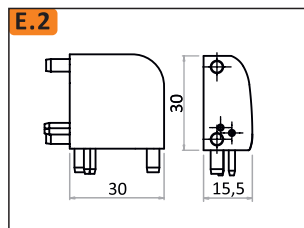

Connector 2
10.01.125.XY/CON2

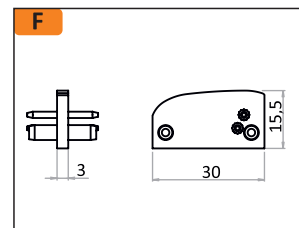

Mounting plate
10.01.125.XY/MP

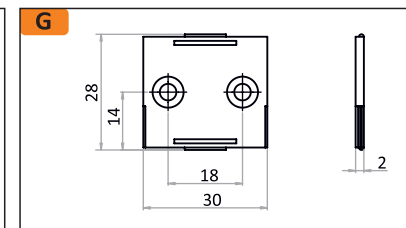

NIKKA SWITCH

10.01.48.XY X: 2 4 8 Y: 1 2 8



NIKKA MOVEMENT

10.01.50.XY X: 2 4 8 Y: 1 2 8



NIKKA PIR

10.01.53.XY X: 2 4 8 Y: 1 2 8

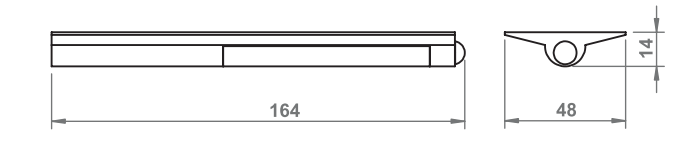
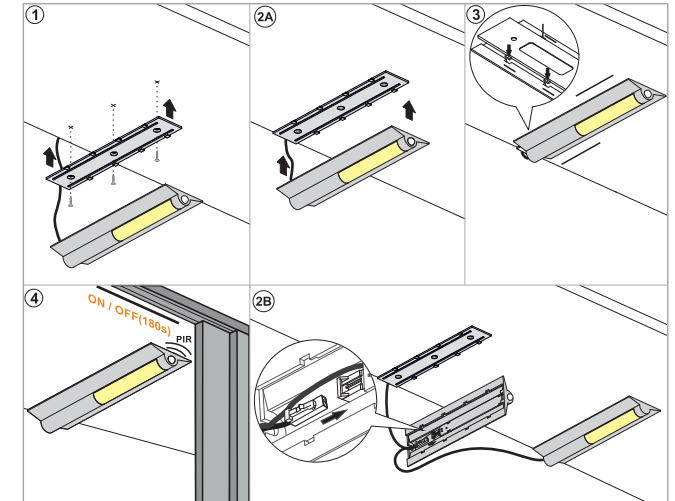
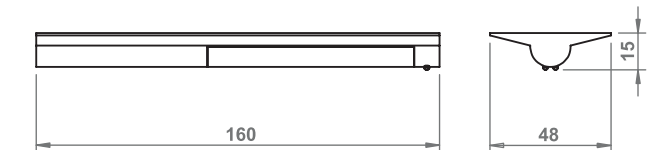
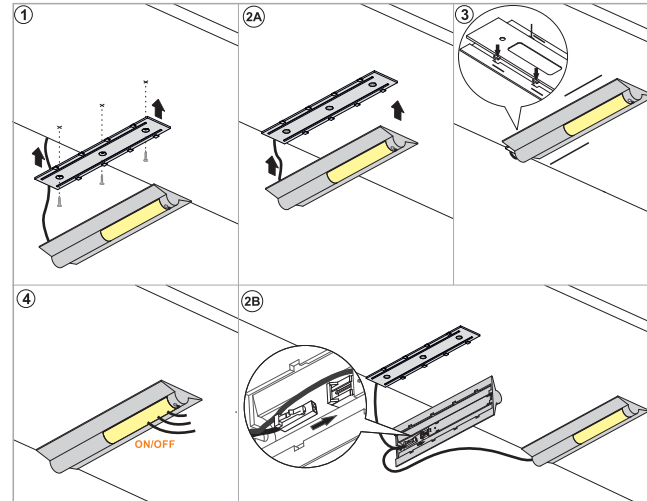
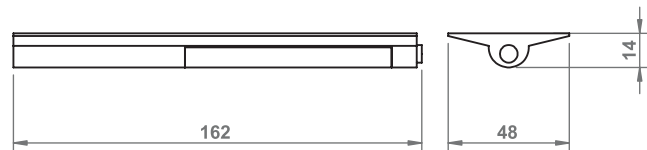
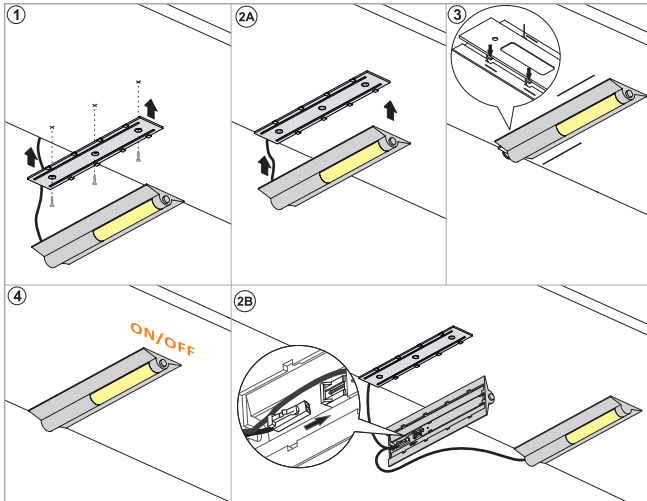

NIKKA DOOR

10.01.101.XY X: 2 4 8 Y: 1 2 8



NEO 2

10.01.52.XY X: 2 Y: 1 2 3 7 8



SQUERE 2S

10.01.20.XY/S X: 2 Y: 1 2 3 7 8

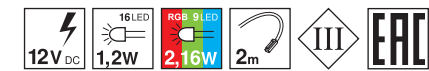
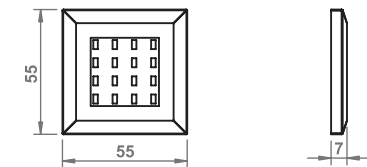
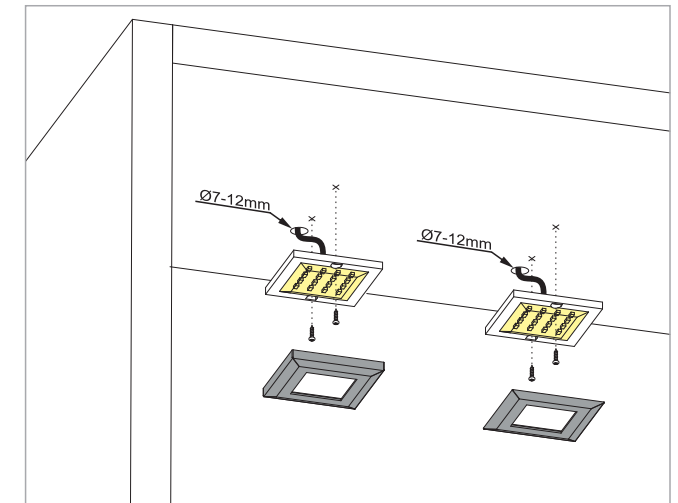
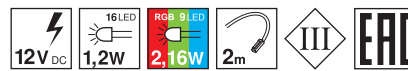
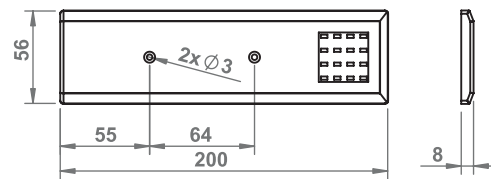
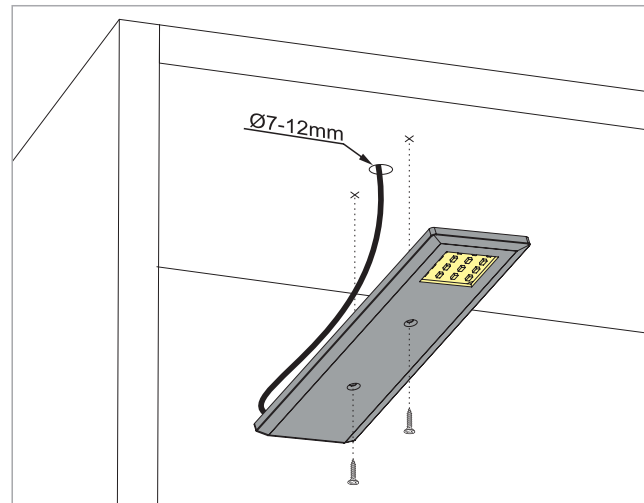
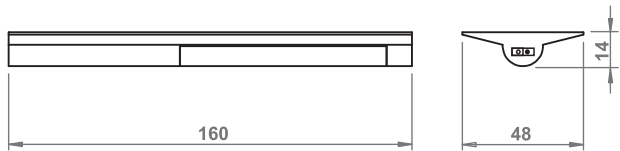
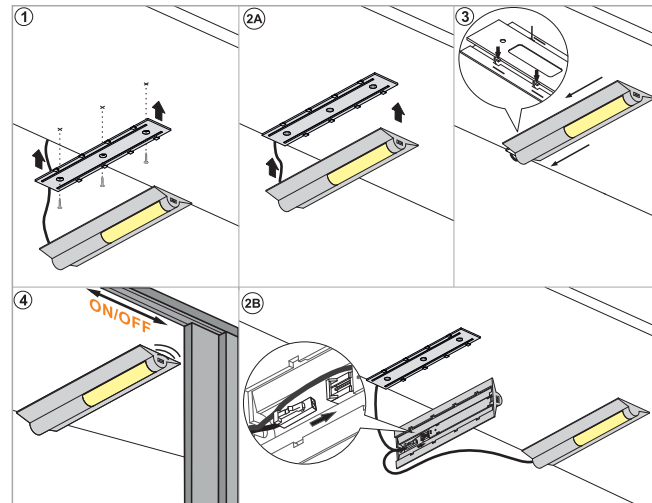
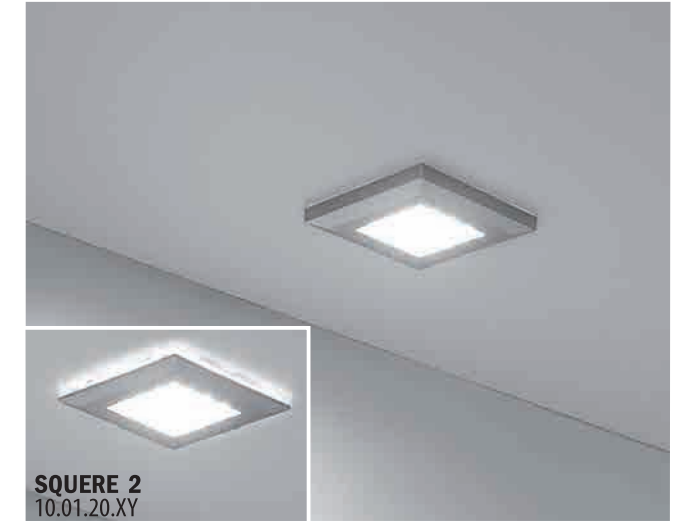

LENA MASTER SWITCH

10.01.36.XY/WM X: 2 4 8 Y: 1 8

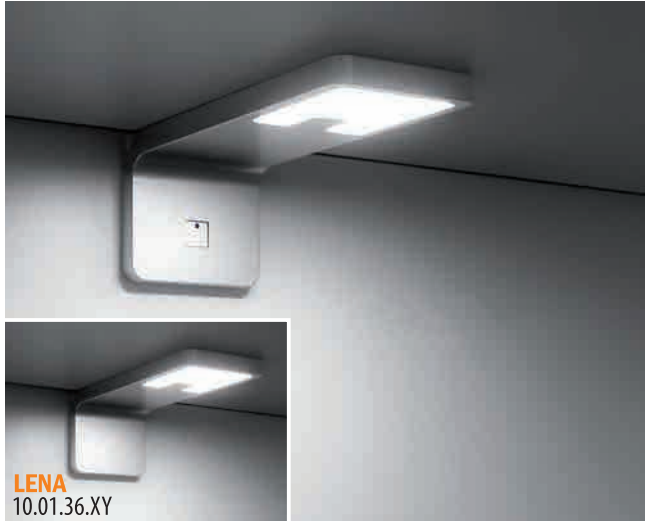

LENA II USB

10.01.99.XY/USB X: 10 11 13 14 Y: 8



LENA II

10.01.99.XY X: 10 11 13 14 Y: 8

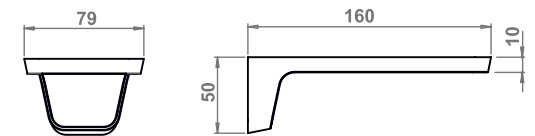
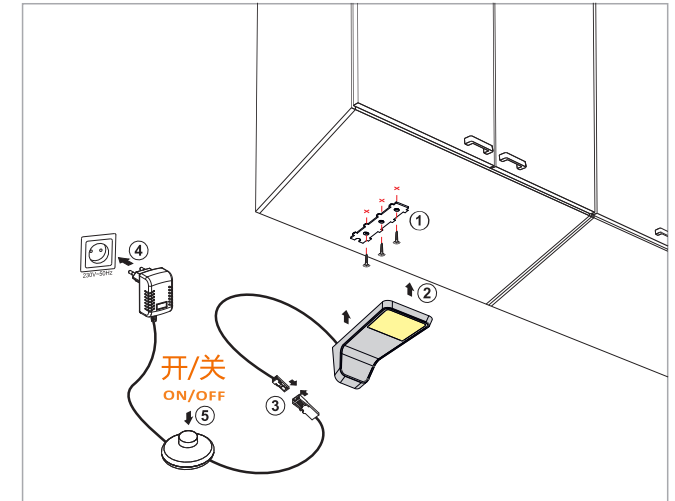
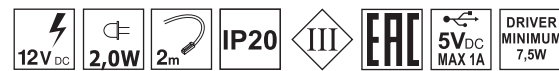
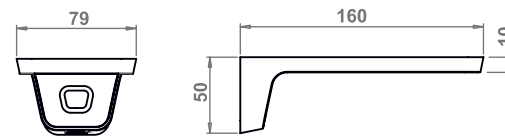
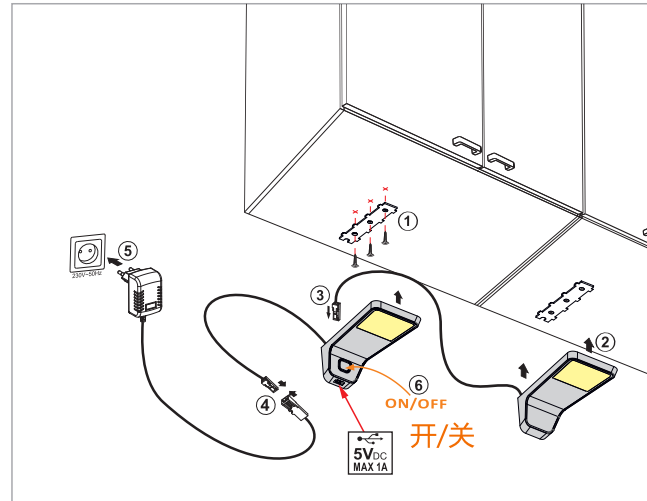
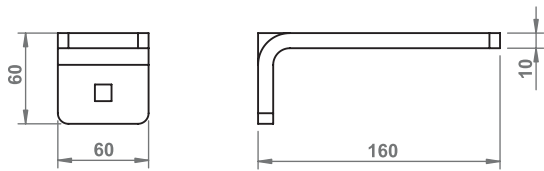
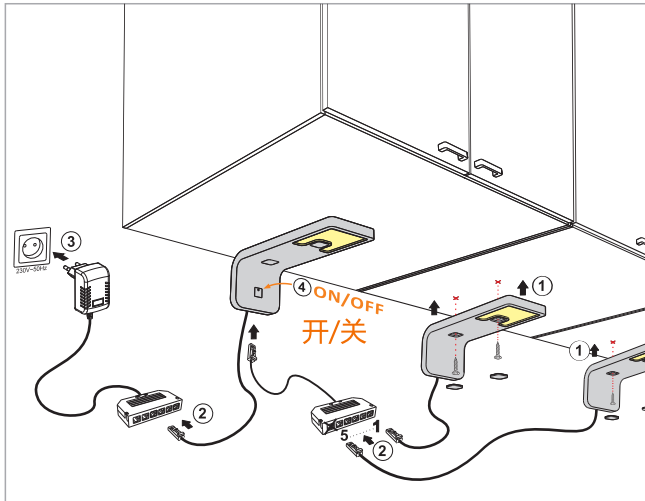

OVO

10.01.65.XY X: 2 4 8 Y: 1 2 8



OVO DY

10.01.65.XY/DY X: 2 4 8 Y: 1 2 8



OVO DYM

10.01.65.XY/DYM X: 2 4 8 Y: 1 2 8

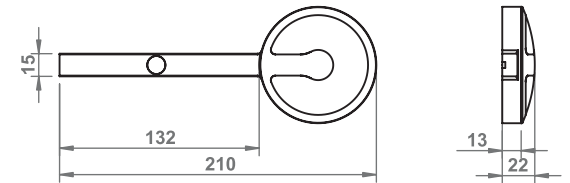
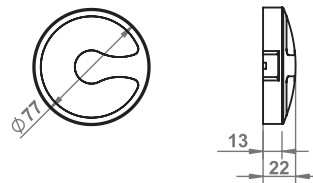
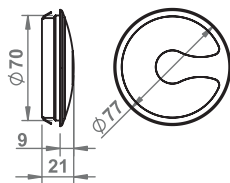
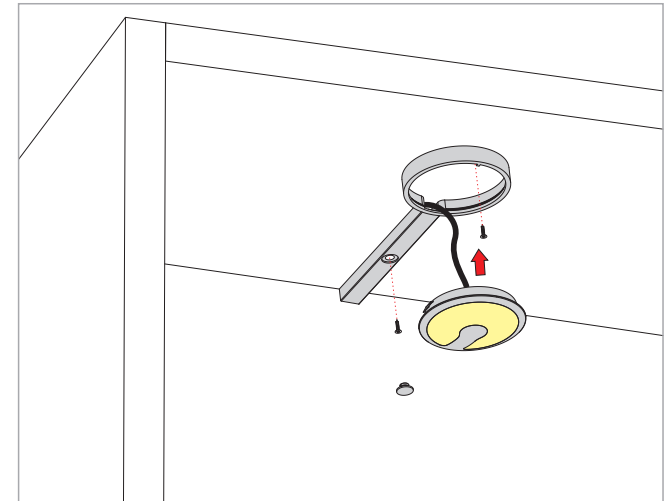
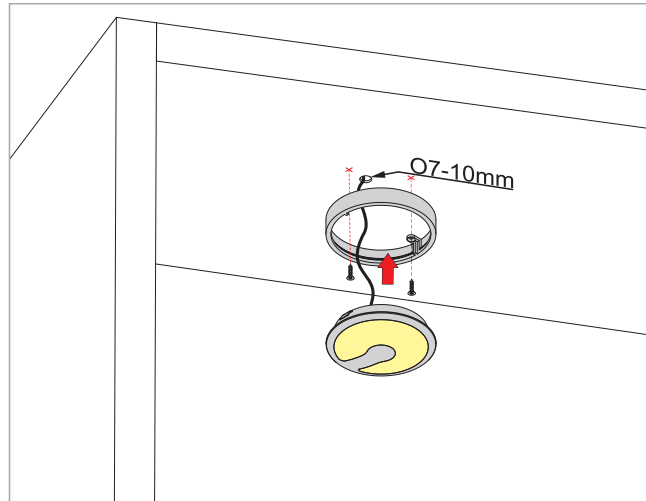
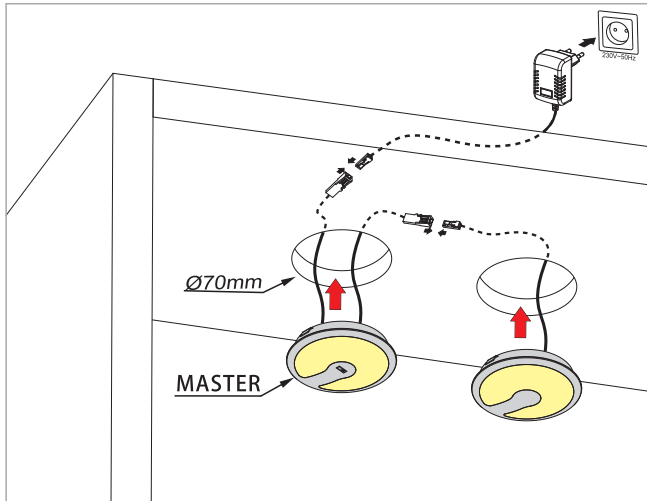

JUNO MOVEMENT

10.01.106.XY/MOV X: 2●4○ Y: 1○2○8○



JUNO

10.01.106.XY X: 2●4○ Y: 1○2○8○



DOMINO

10.01.102.XY X: 2●4○8● Y: 8○

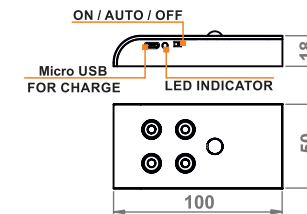
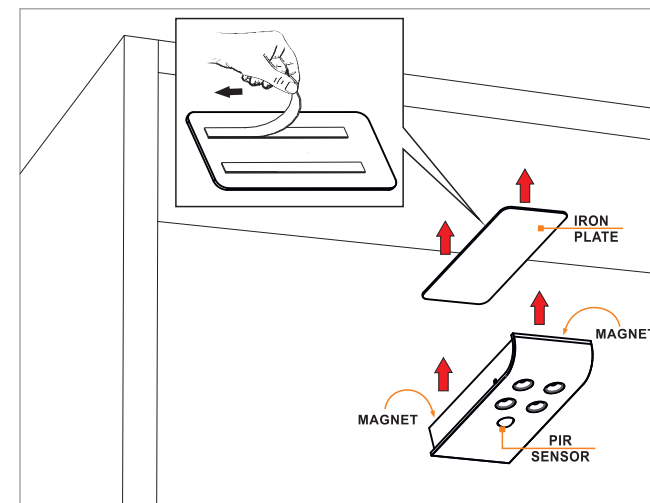
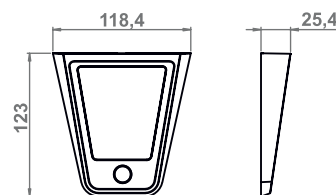
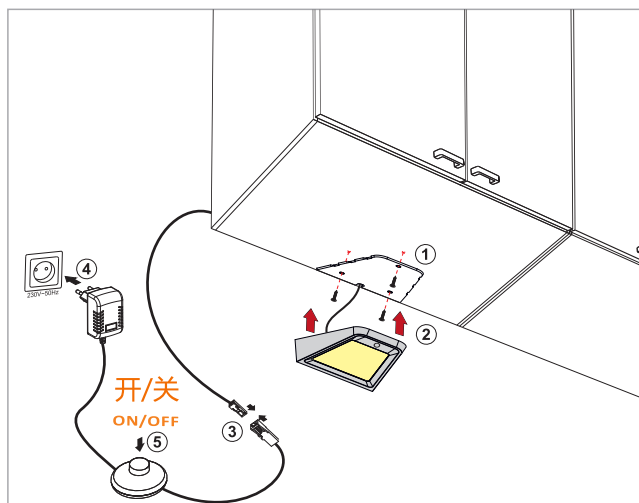
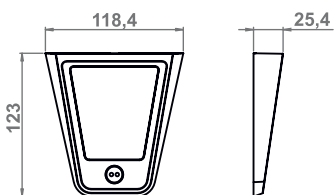
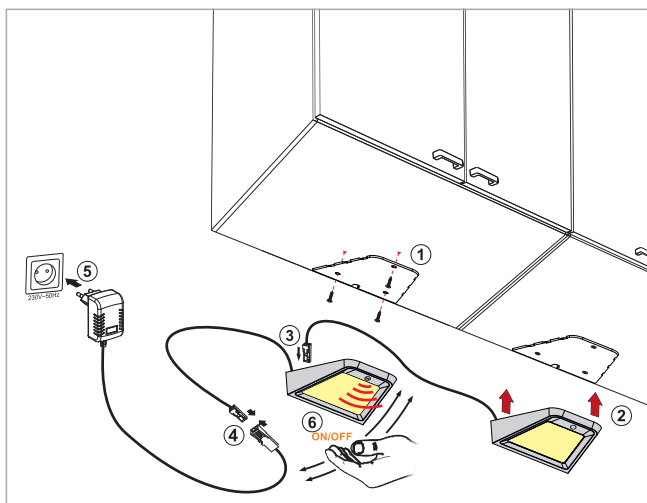

MAYA

10.01.72.XY X: 2●8● Y: 1○2○8○



MAYA H/2m

10.01.72.XY/H/2m X: 2●8● Y: 1○2○8○



MAYA DY

10.01.72.XY/DY X: 2●8● Y: 1○2○8○

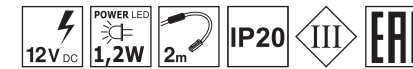
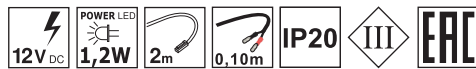
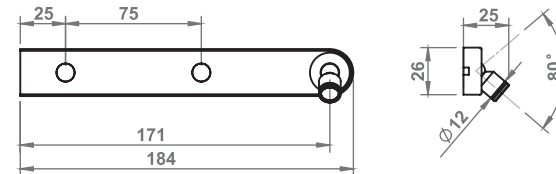
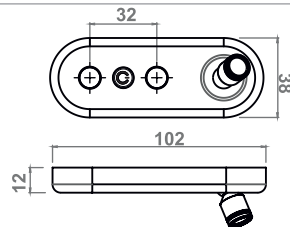
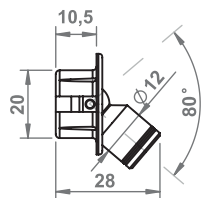
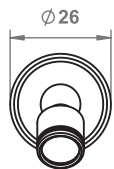
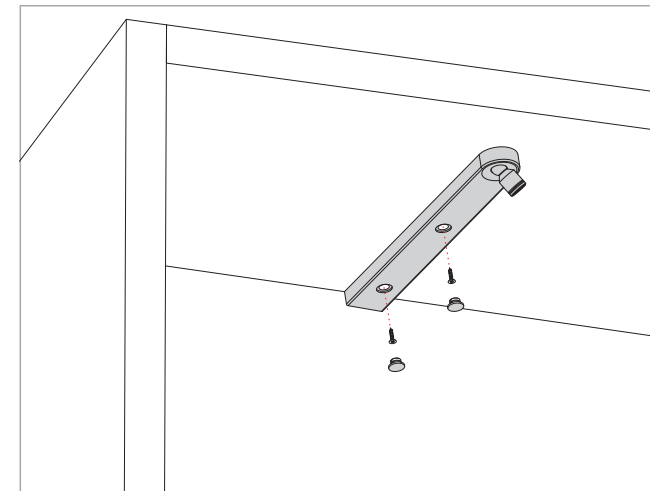
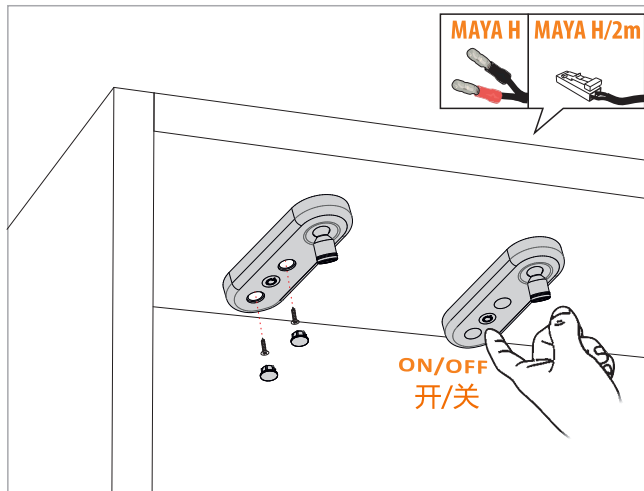
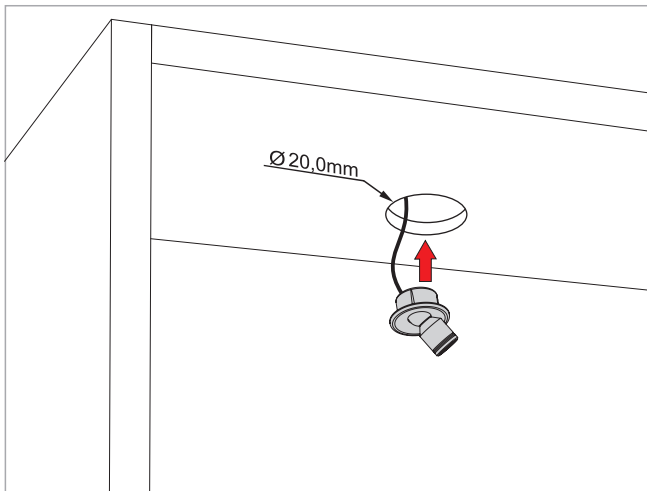

FLASH

10.01.30.XY X: 2 ● Y: 1 ○ 2 ●
3 ● 8 ○

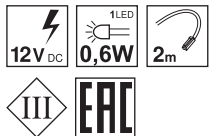
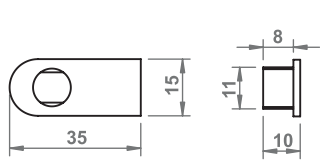
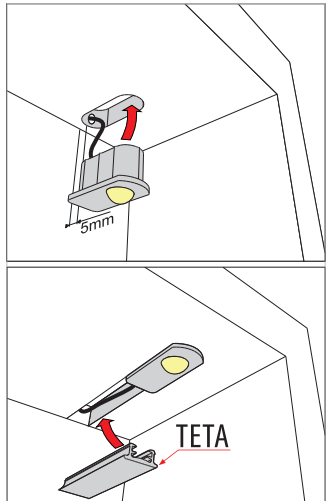

POINT

10.01.22.XY X: 2 ● Y: 1 ○ 2 ● 8 ○

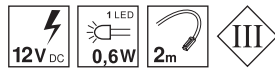
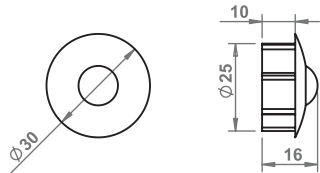
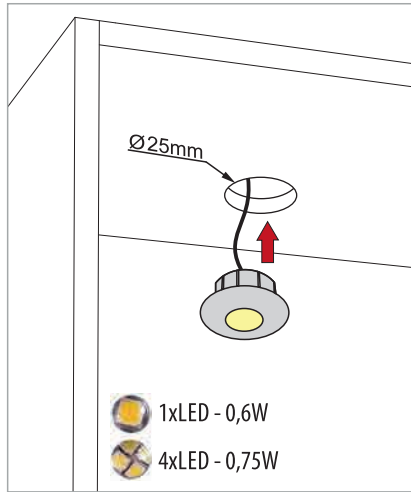

BIG POINT

10.01.86.XY X: 1 ● Y: 1 ○ 2 ● 8 ○

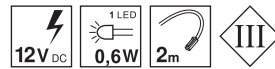
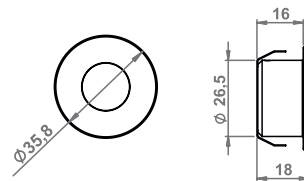
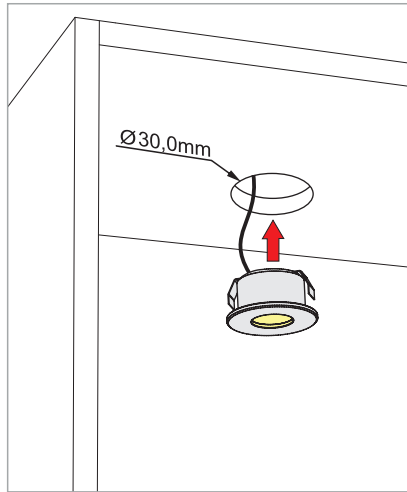

MINI LENS

10.01.112.XY X: 2 ● Y: 1 ○ 2 ● 8 ○

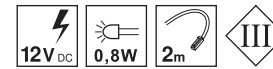
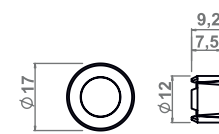
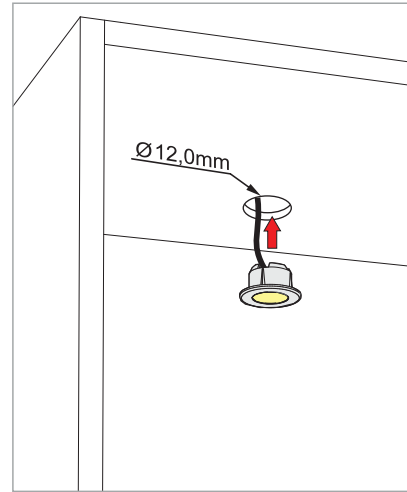

MINI POINT

10.01.76.XY X: 2 ● 8 ● Y: 1 ○ 2 ● 8 ○

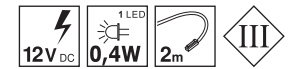
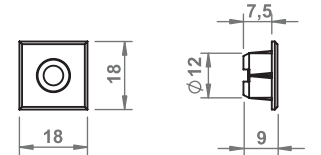
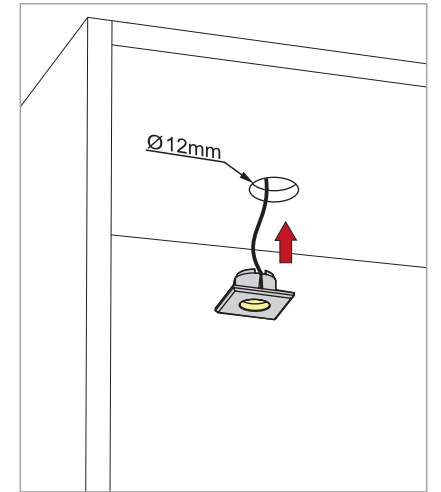

QUAD

10.01.77.XY X: 1 ● 2 ○ 4 ○ 8 ● Y: 1 ○ 2 ○ 8 ○

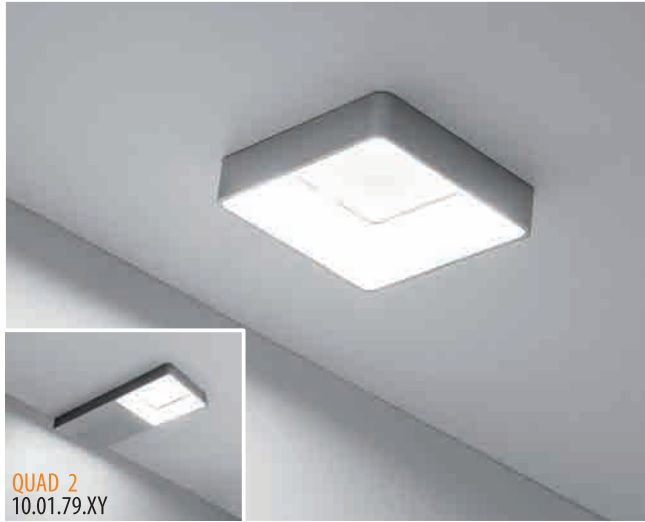

SPACE

10.01.78.XY X: 1 ● 2 ○ 4 ○ 8 ● Y: 1 ○ 2 ○ 8 ○



ADA

10.01.84.XY X: 2 ○ Y: 1 ○ 8 ○

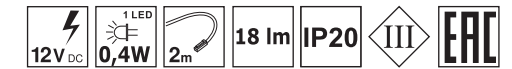
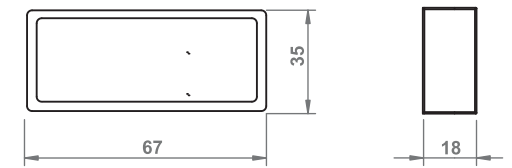
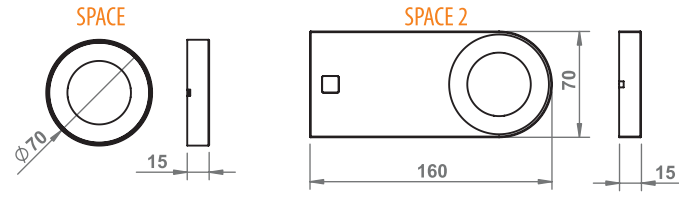
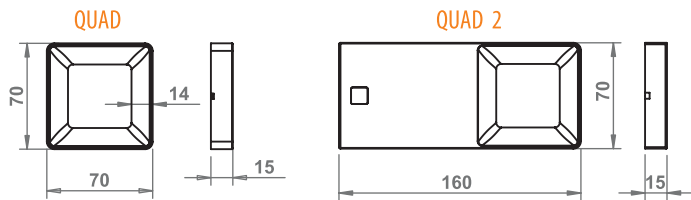
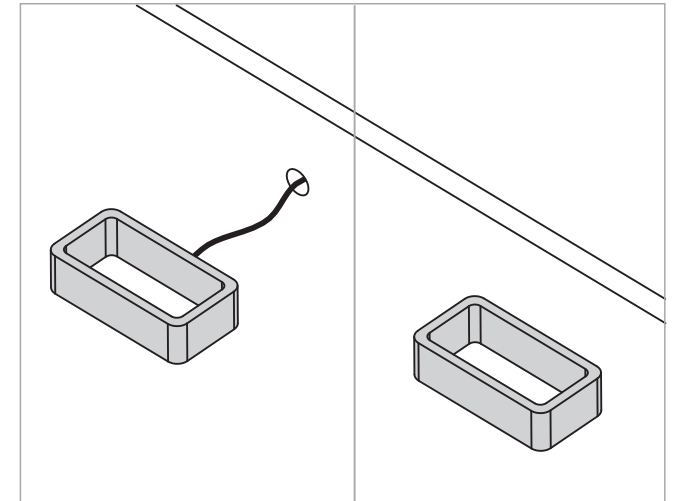
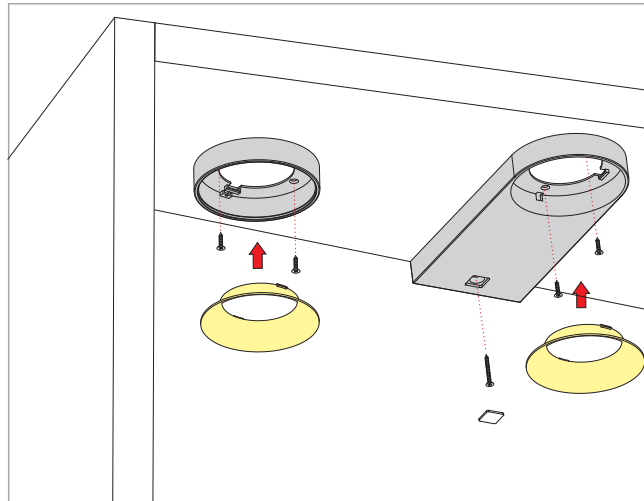
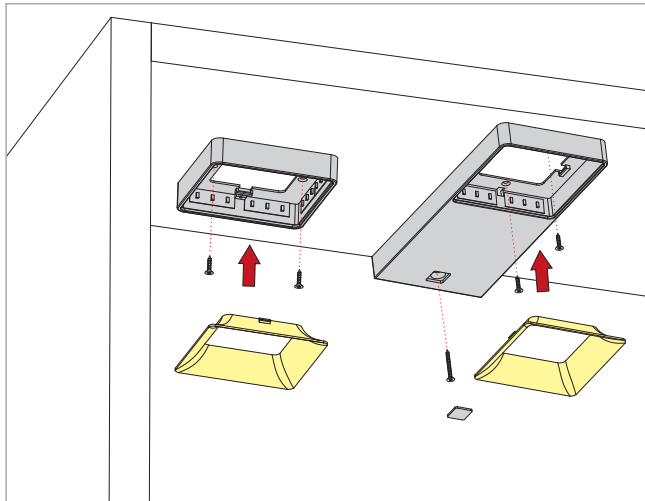

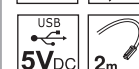
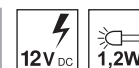
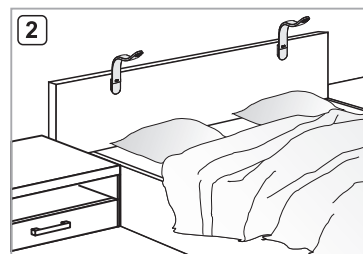
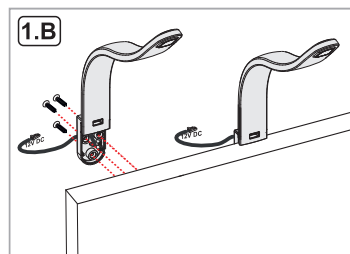
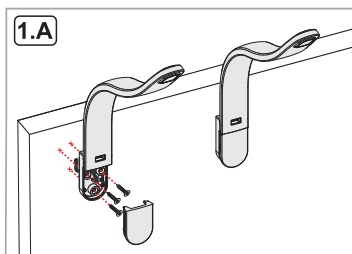

OUT: 1xUSB 5VDC MAX 1A

DRIVER MINIMUM 15W

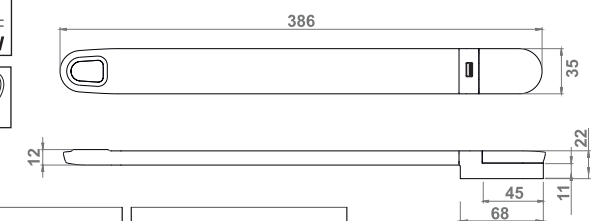

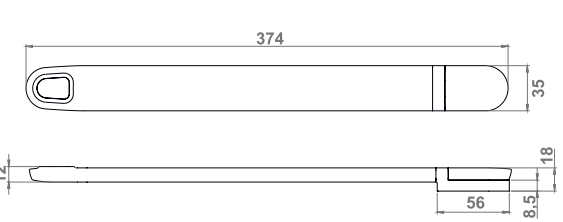
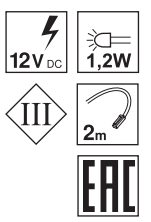
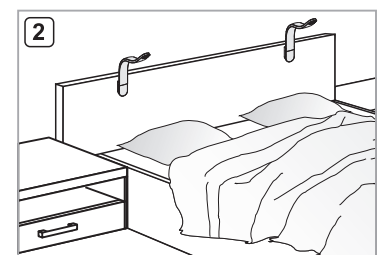
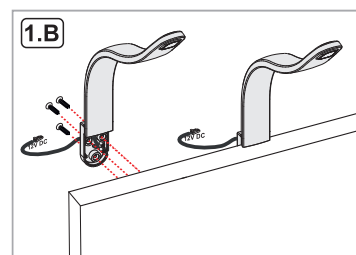
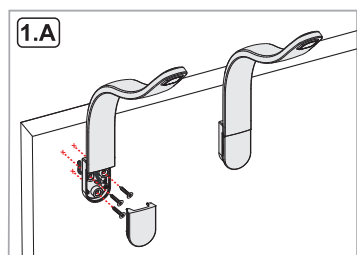
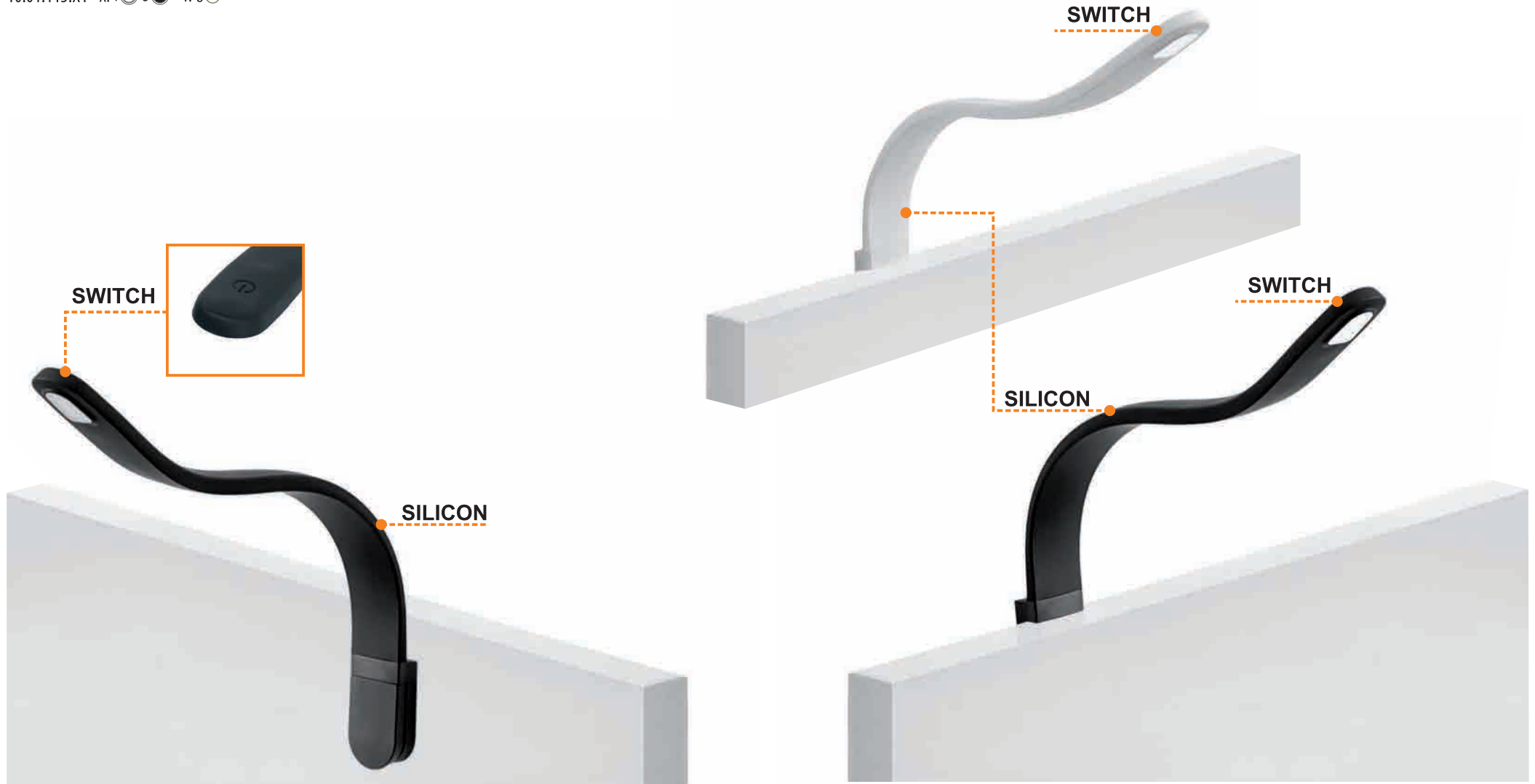

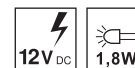
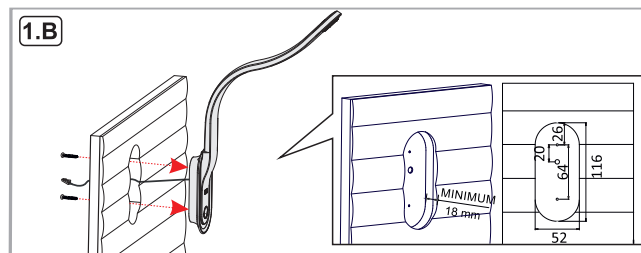
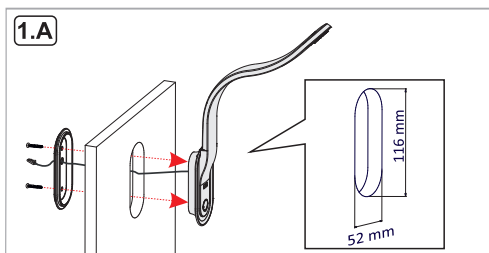

OUT: 1xUSB 5VDC MAX 1A

DRIVER MINIMUM 15W

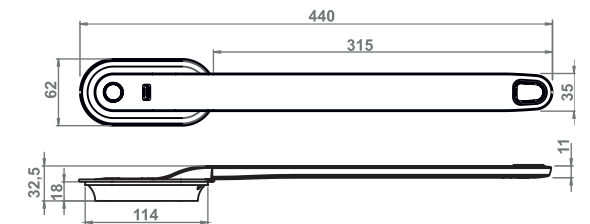

10.01.134.XY X: 2 8 Y: 8

10.01.134.XY/CAMPER X: 2 8 Y: 8

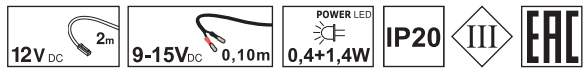
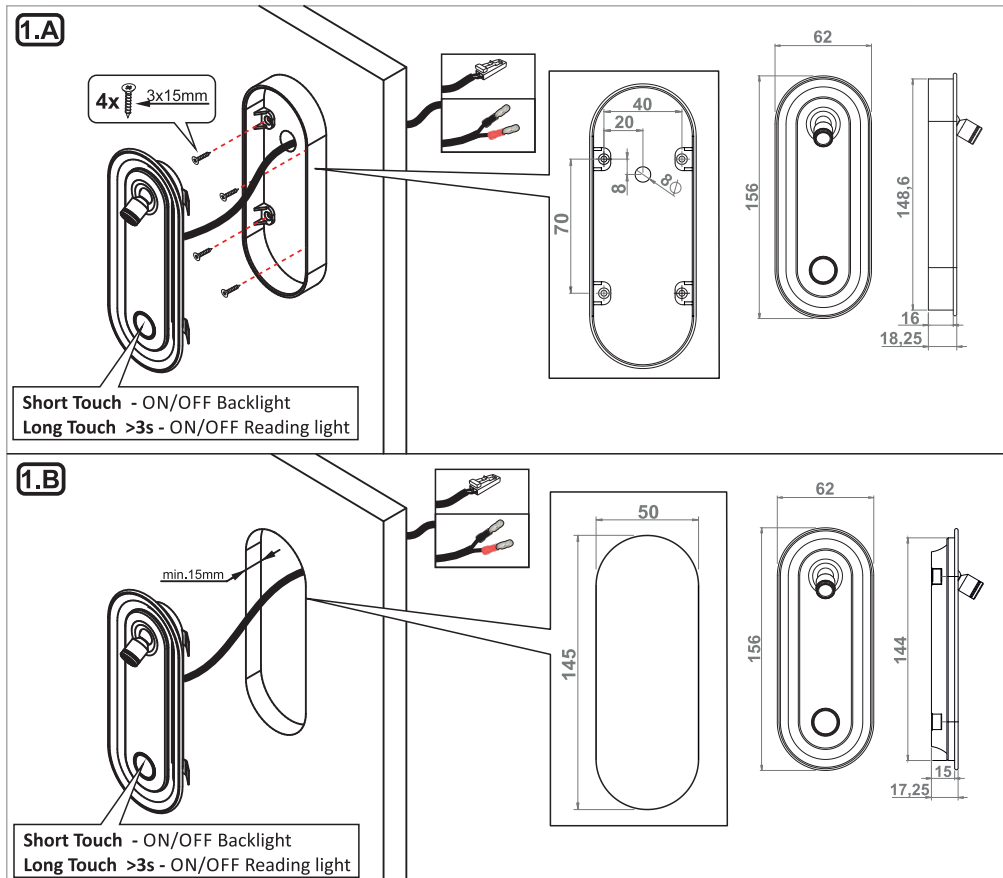

FLEXI Q

10.01.92.XY X: 9 10 11 12 13 14 Y: 1 0 8 0

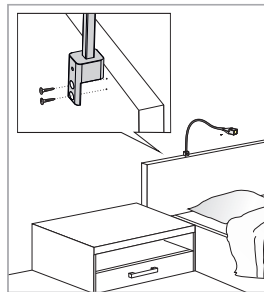
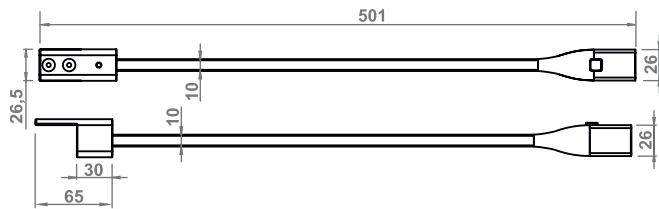
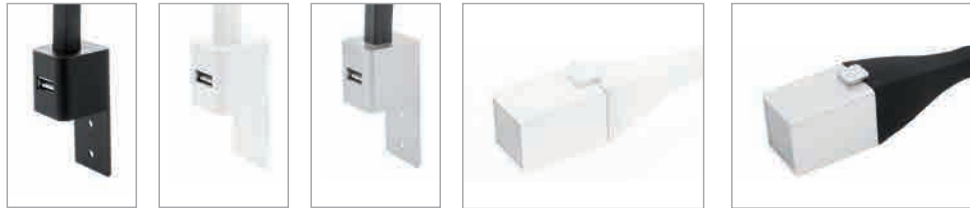

FLEXI H / FLEXI RH

10.01.104.XY/H X: 9 10 11 12 13 14 Y: 1 0 8 0

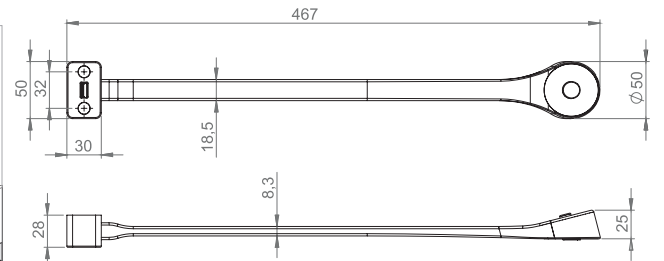
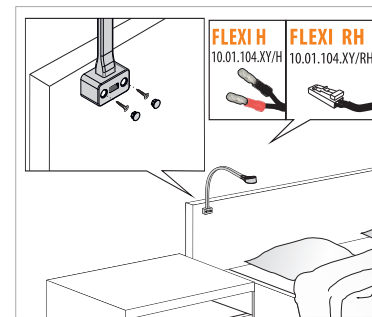



reddot award 2017
winner lighting design

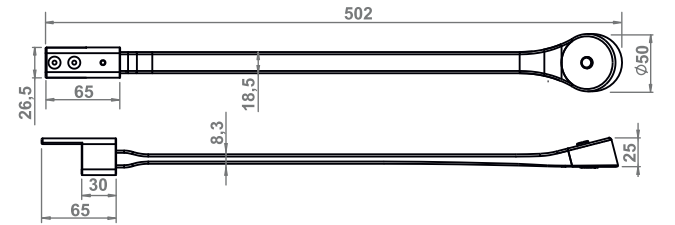
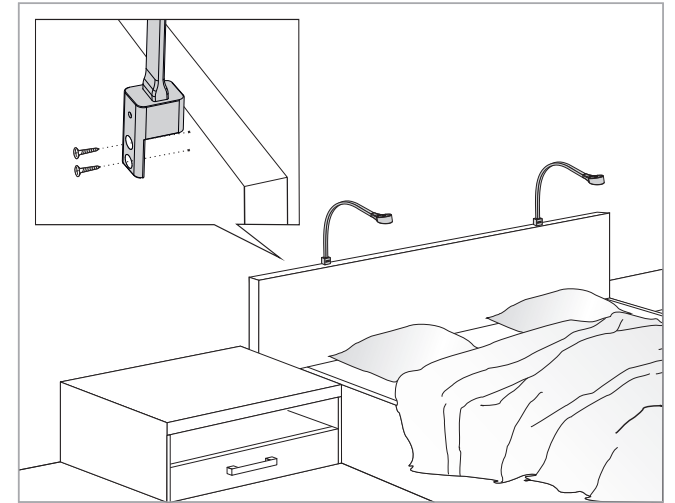

12V DC	12 LED 1,8W	2m	IP20	III	EAC	5V DC MAX 1A	DRIVER MINIMUM 7,5W
--------	----------------	----	------	-----	-----	-----------------	---------------------------

ETA

10.01.39.XY X: 1 ● 2 ○ 4 ○ 8 ● Y: 1 ○

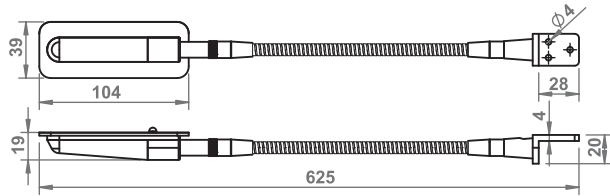
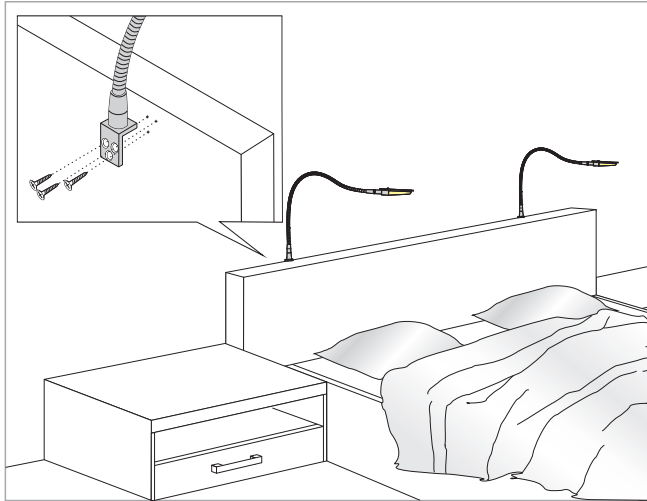

BUTTERFLY

10.01.46.XY X: 1 ● 2 ○ 4 ○ 8 ● Y: 1 ○

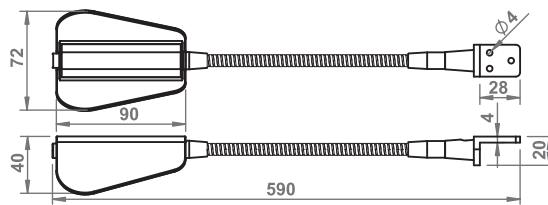
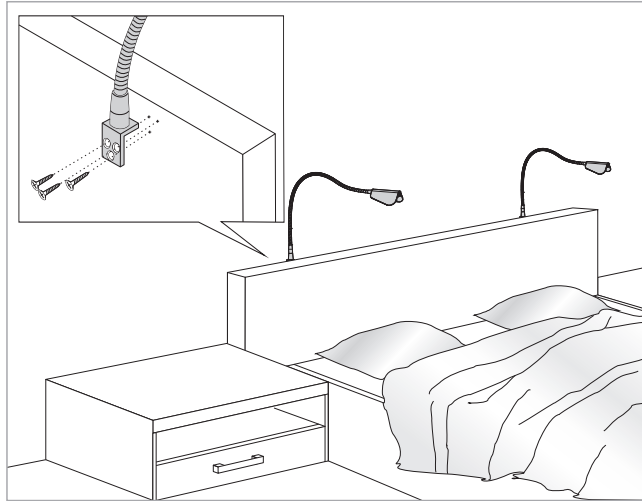

GABI Q

10.01.87.XY X: 2 ○ 4 ○ 8 ● Y: 1 ○ 2 ○ 8 ○

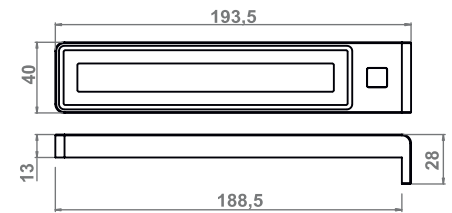
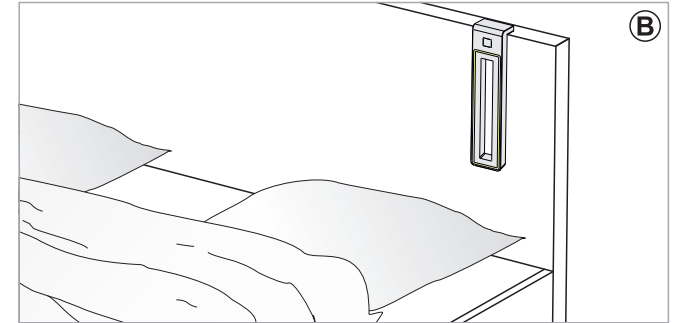
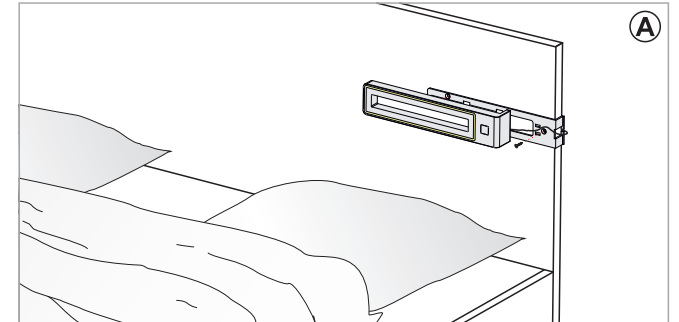

GABI Q-P

10.01.87.XY/Q/P X: 2 4 8 Y: 1 2 8

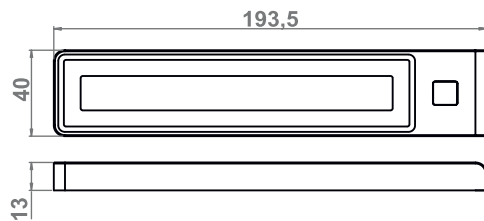
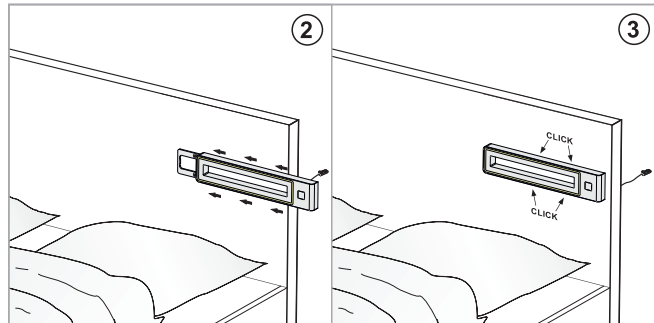
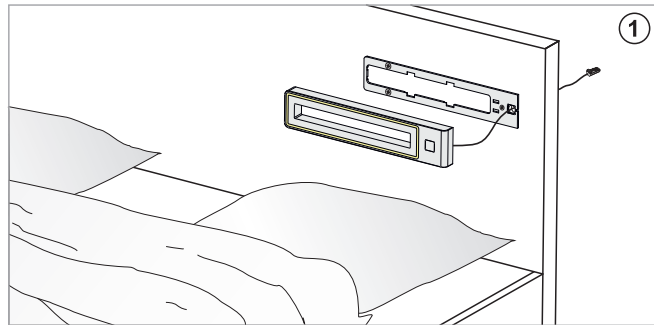

12V DC 42 LED 3,0W 2m IP20 III EAC

GABI R

10.01.88.XY X: 2 4 8 Y: 1 2 8

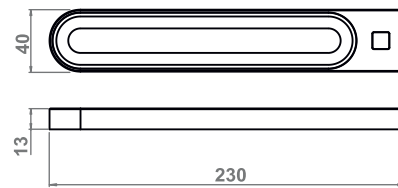
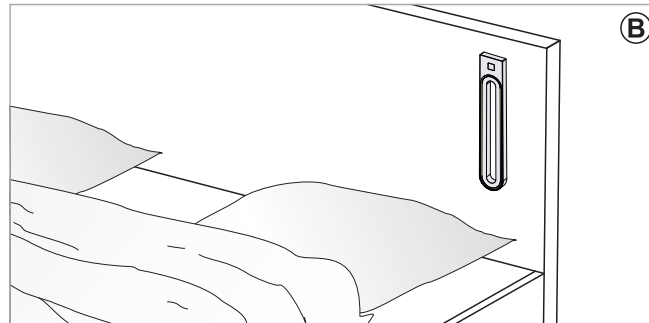
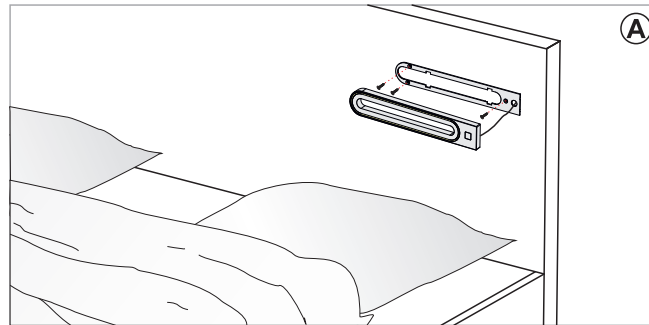

12V DC 42 LED 3,0W 2m IP20 III EAC

GABI R/USB

10.01.88.XY/USB X: 2 4 8 Y: 1 2 8

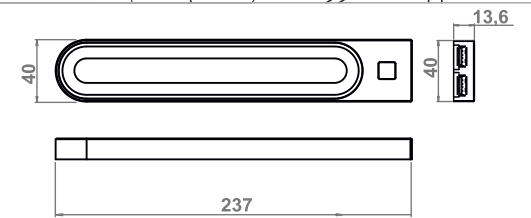
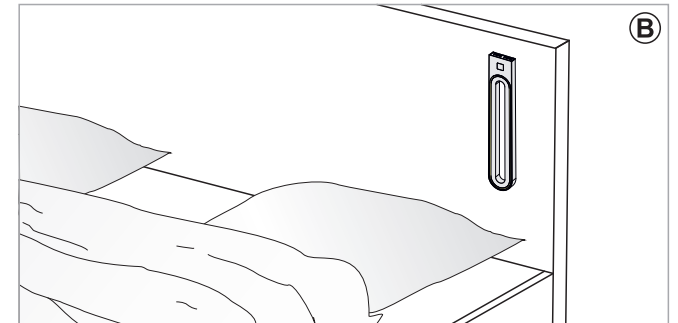
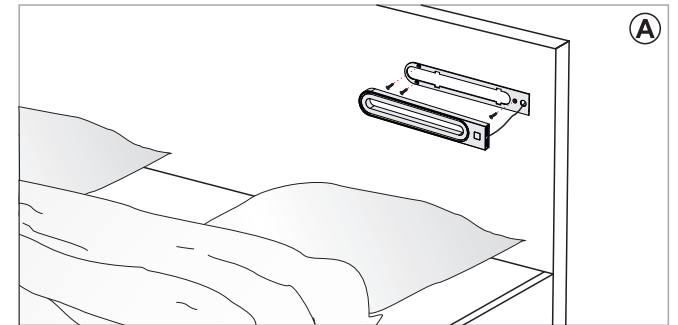

12V DC 42 LED 3,0W 2m IP20 III EAC 5V DC MAX 1A DRIVER MINIMUM 15W

COMA

10.01.109.XY X: 2 4 8 Y: 1 2 8

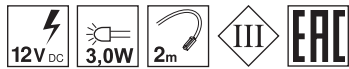
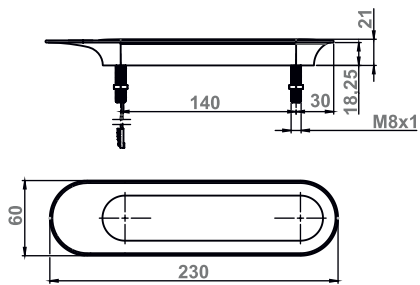
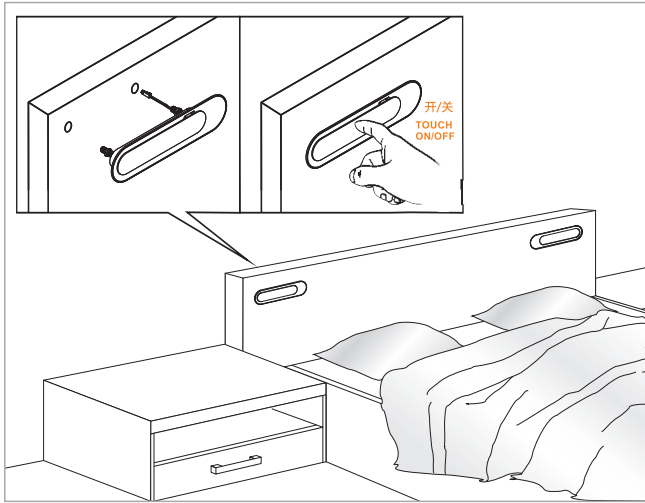
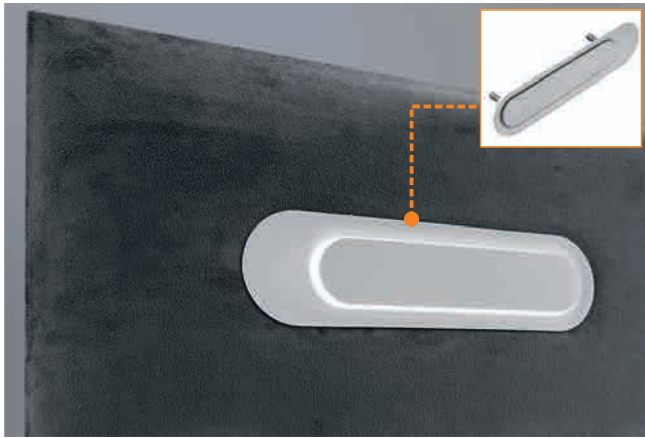

INLINE

10.01.111.XY X: 1 2 4 8 Y: 1 2 8

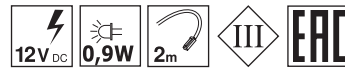
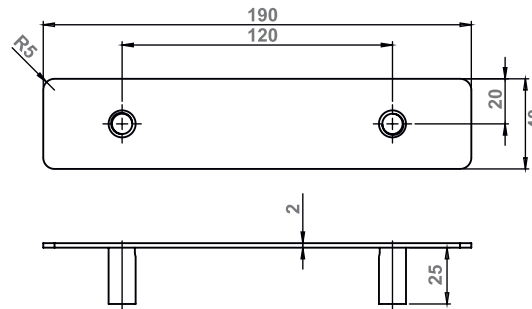
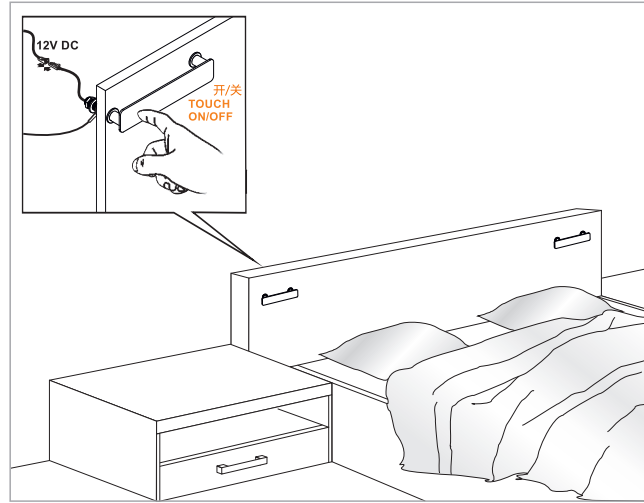
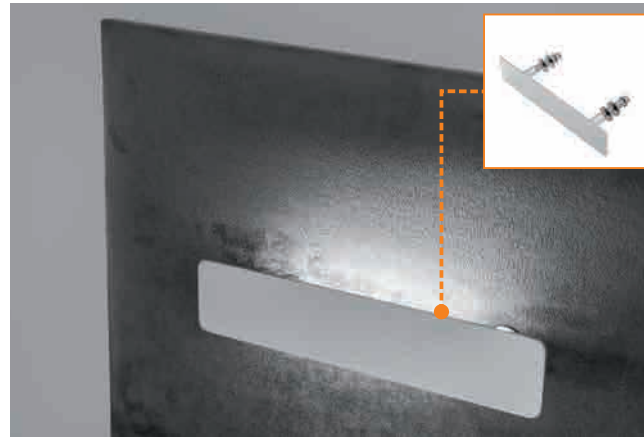

INLINE-L

10.01.110.XY X: 1 2 4 8 Y: 1 2 8

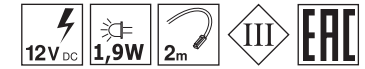
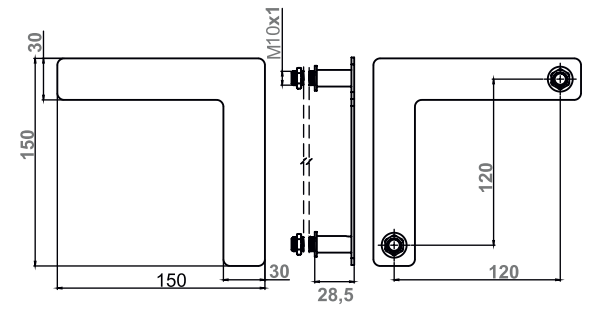
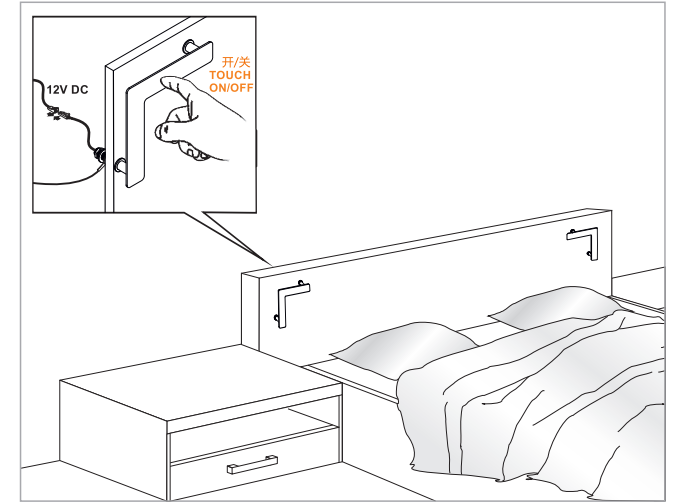

COMA COM

10.01.144.XY X: 2 4 8 Y: 1 2 8

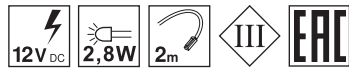
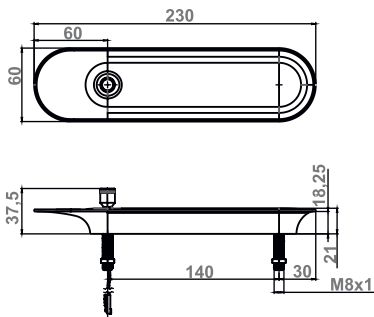
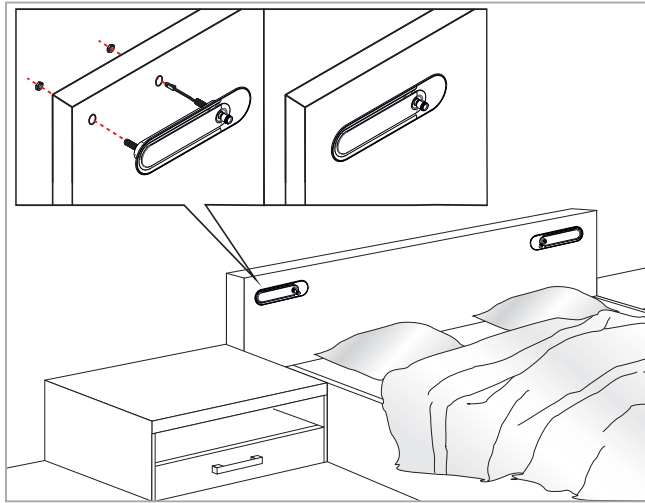

PEAK

10.01.114.XY X: 2 8 Y: 8

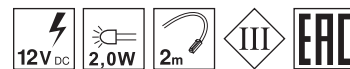
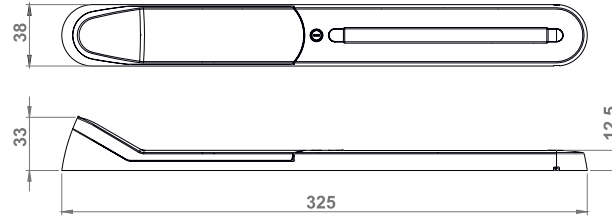
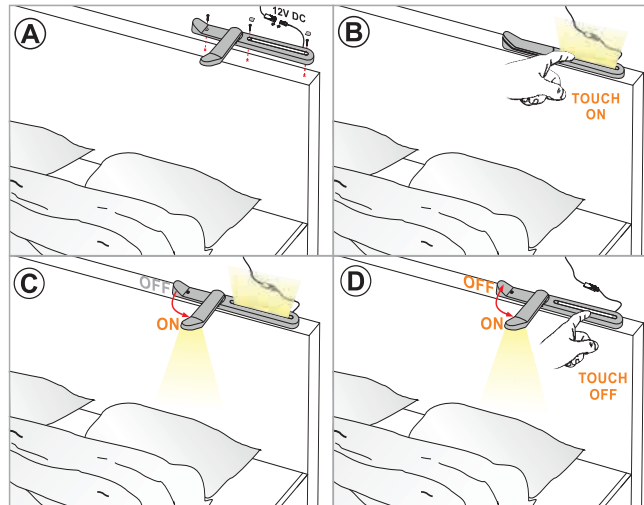

KINKIET

10.01.153.XY X: 2 4 8 Y: 8

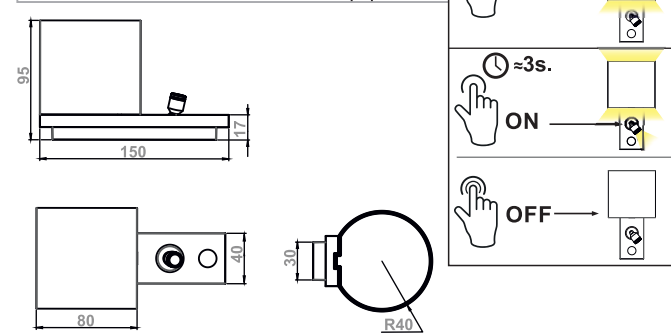
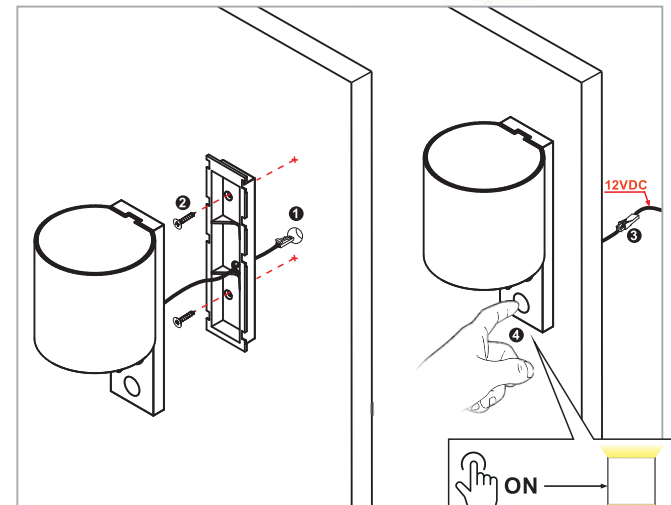

WIRELESS CHARGER / FWC-1000

10.05.13/FWC-1000

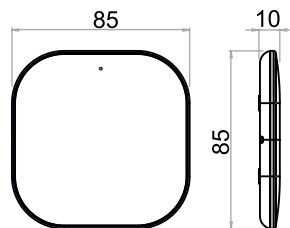
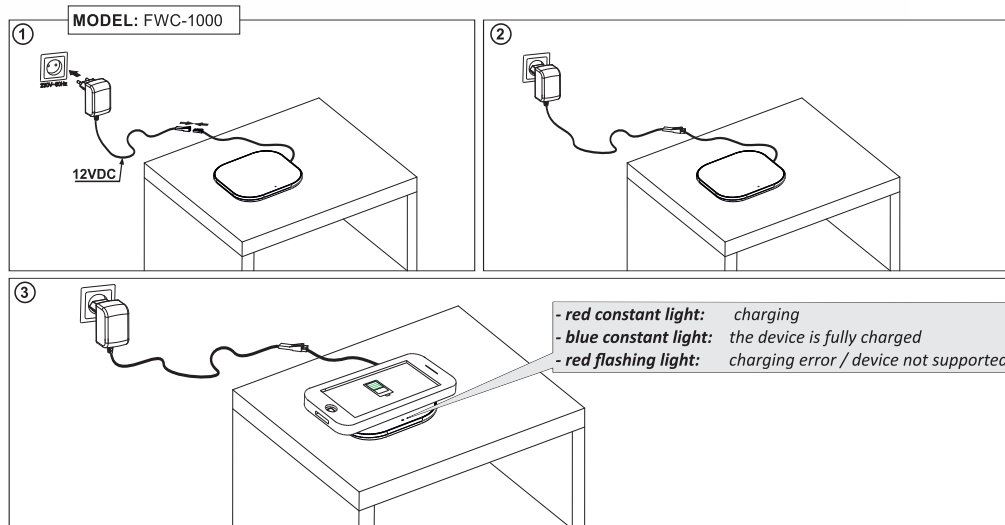

WIRELESS CHARGER / FWC-1100 (screw)

10.05.13/FWC-1100

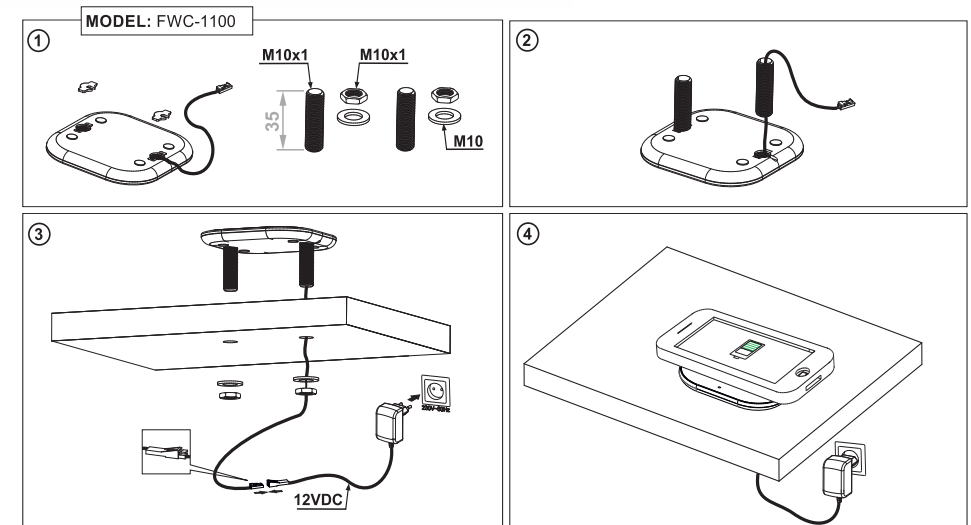

INPUT: 12VDC
OUTPUT: 5V-1A

Charging standard: Qi WPC V1.4.2

Recommended power of the power supply unit: 15W

Maximum energy consumption of the charger: 1.25 A

Maximum power of the charger: 5 W (5 V 1 A) / 7.5 W for Iphone / 10 W for Samsung

WIRELESS CHARGER POD /FWC-1200

10.05.13.X/FWC-1200 X: 8 ●

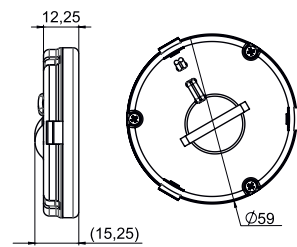
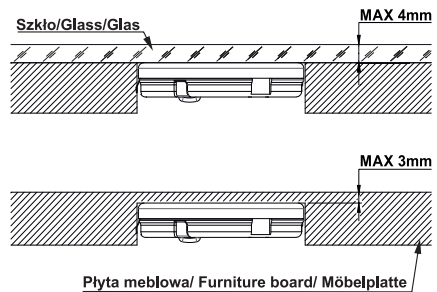
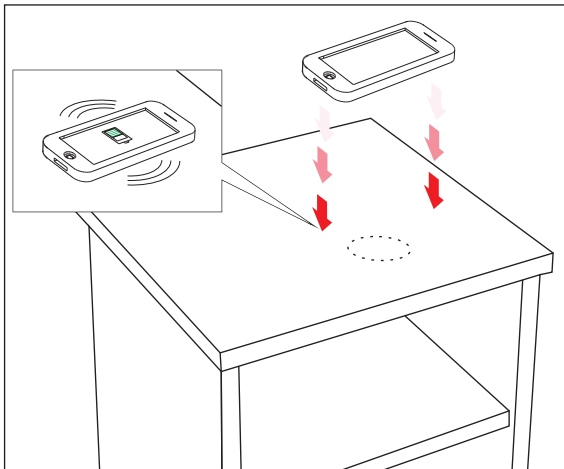
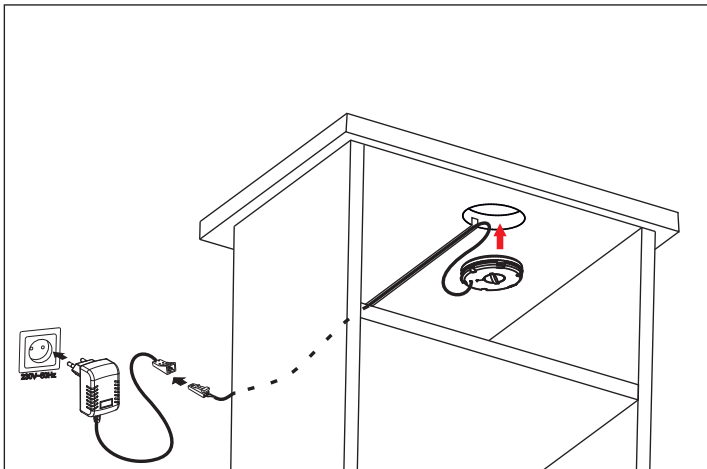

INPUT: 12VDC
OUTPUT: 5V-1A



USB /T CHARGER

10.05.13.X/T X: 2 ● 4 ● 8 ● 10 ● 13 ●
/USB Charger / USB-Ladegerät / USB зарядное устройство

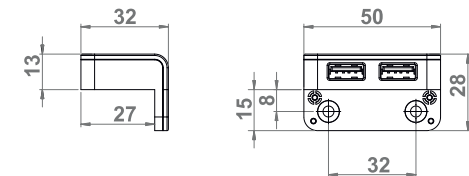
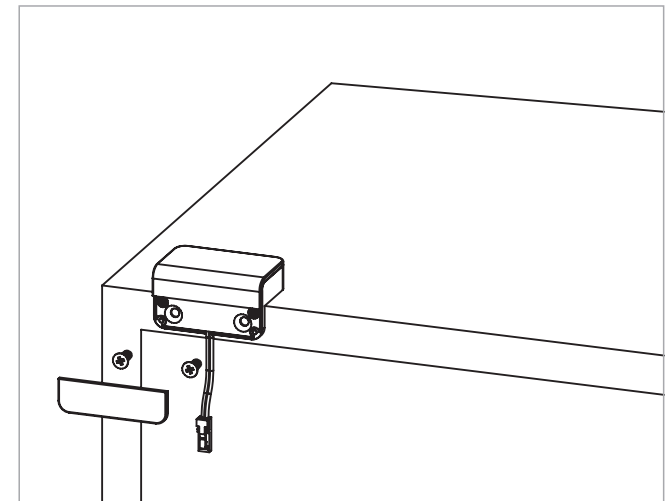

IN: 12VDC
OUT: 2 x USB 5VDC MAX 2x1A

DRIVER
MINIMUM
15W

USB CHARGER

10.05.13.X X: 2 4 8 /USB Charger / USB-Ladegerät / USB зарядное устройство

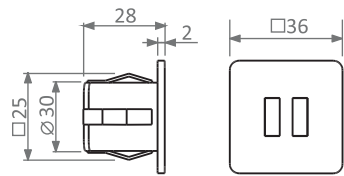
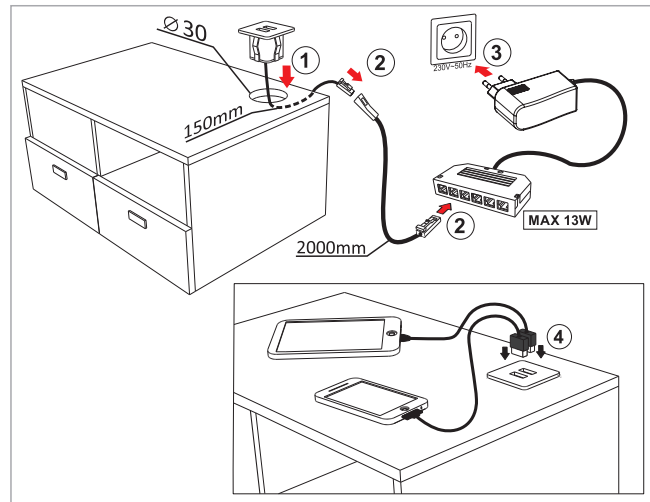

USB/R CHARGER

10.05.13.X/R X: 2 4 8 /USB Charger / USB-Ladegerät / USB зарядное устройство

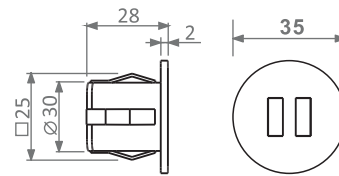
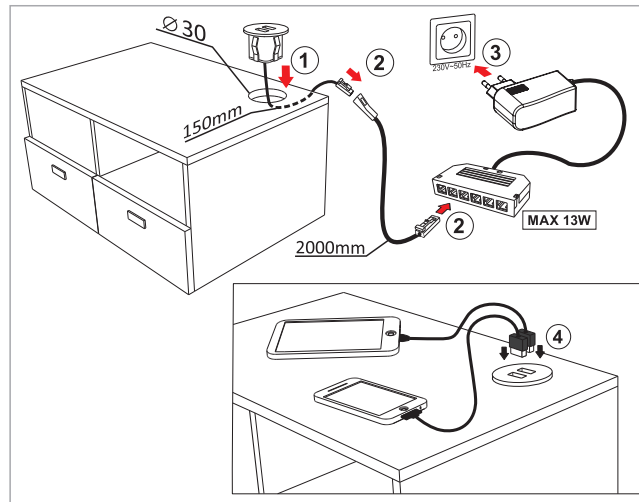

DOUBLE USB SWITCH

10.05.25.X X: 2 4 8

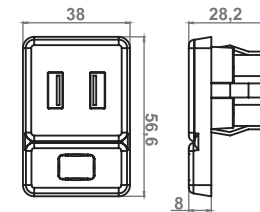
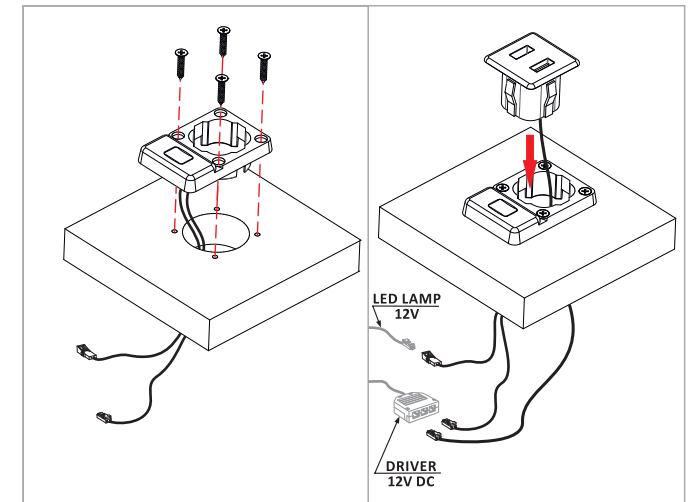

USB-SWITCH

10.05.18.X X: 2 4 8

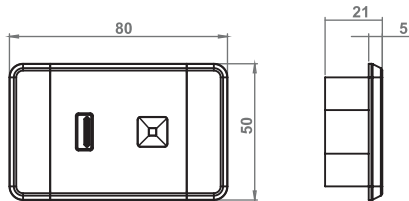
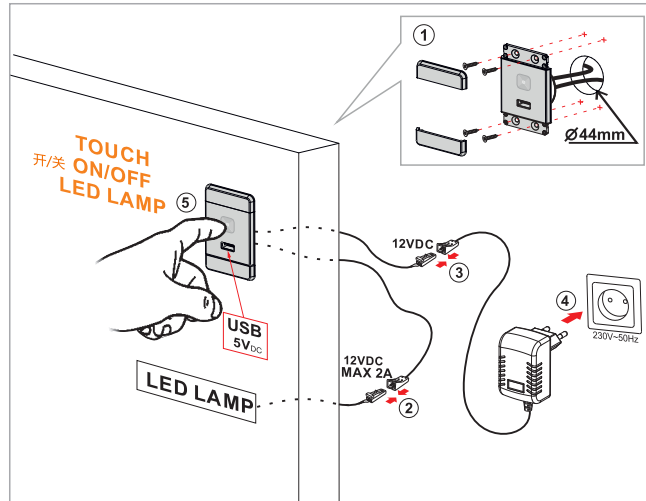
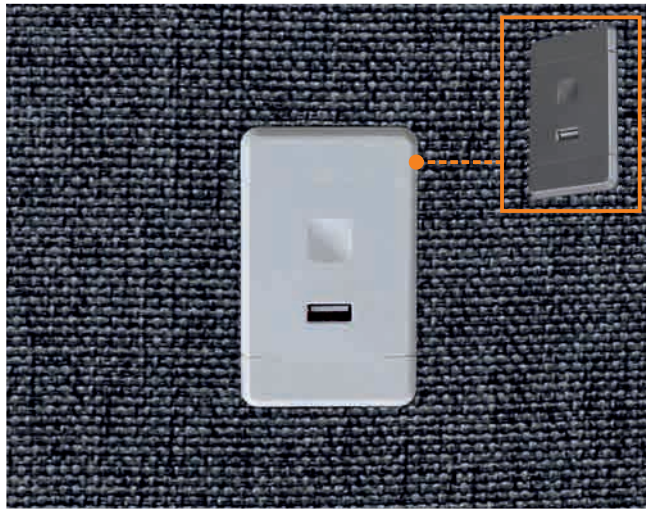

IN: 12VDC
 OUT: 1xUSB 5VDC MAX 2A
 DRIVER MINIMUM 15W

LILI

10.01.74.XY X: 4 8 Y: 1

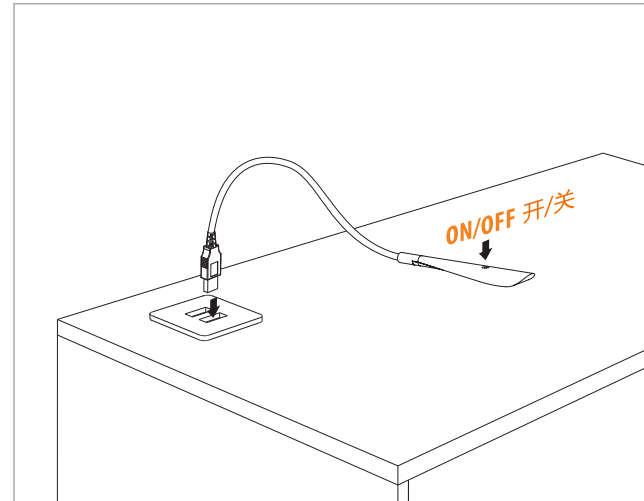

LEG P50 / LEG L / LEG P25

X: 1 2 8 Y: 1 2 3 4 5 6 7
/corner to the sofa leg/LED Füß/нога угловая для софы

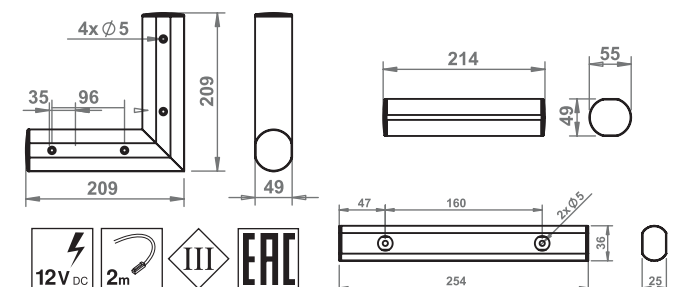
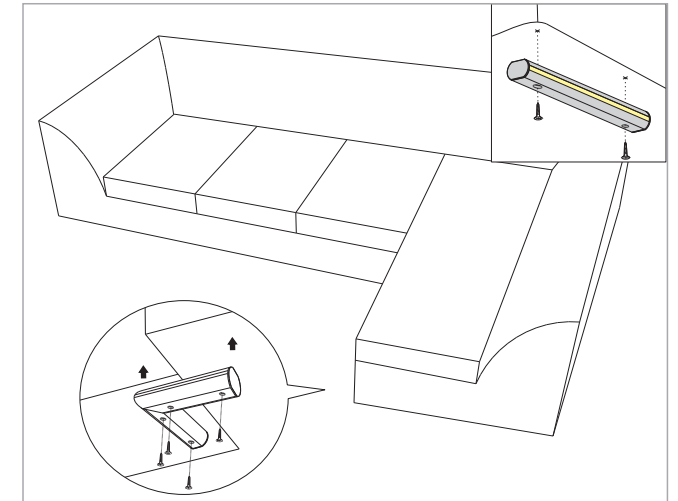

LEG HC

10.01.56.XY X: 1 2 3 4 5 6 7 8 Y: 1 2 3 4 5 6 7
/corner to the sofa leg/LED Füß/нога угловая для софы



LEG H

10.01.57.XY X: 1 2 3 4 5 6 7 8 Y: 1 2 3 4 5 6 7



STAR LED

10.01.85.XY X: 1 4 8 Y: 1

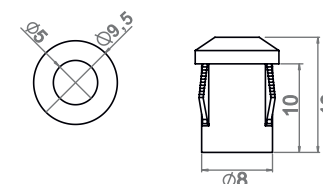
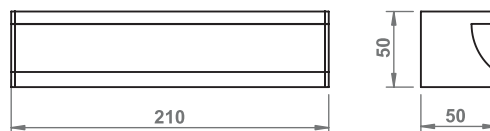
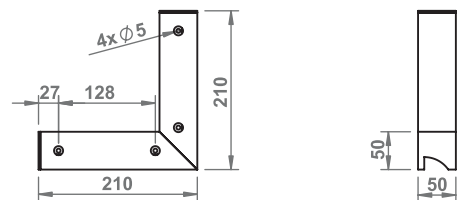
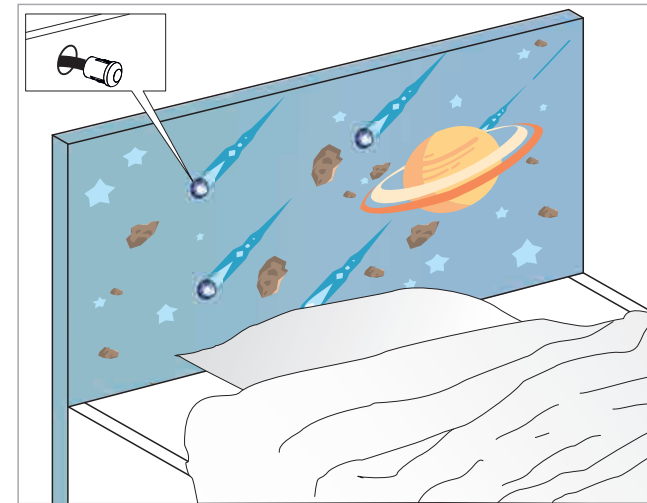
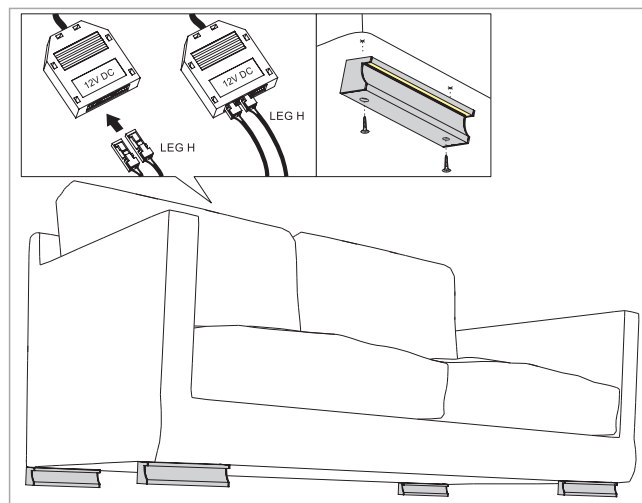
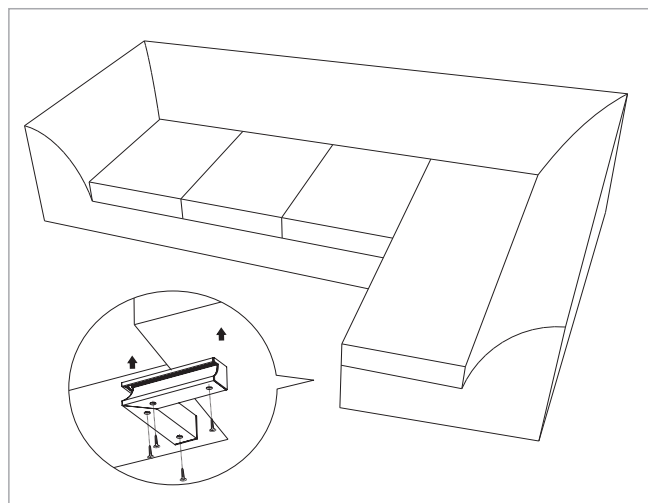

NEON 8x15 FLEX

10.01.89.XY/G/8x15 X: 5 ● Y: 1 ○ 2 ○ 3 ● 4 ● 5 ● 6 ● 8 ○ 9 ●

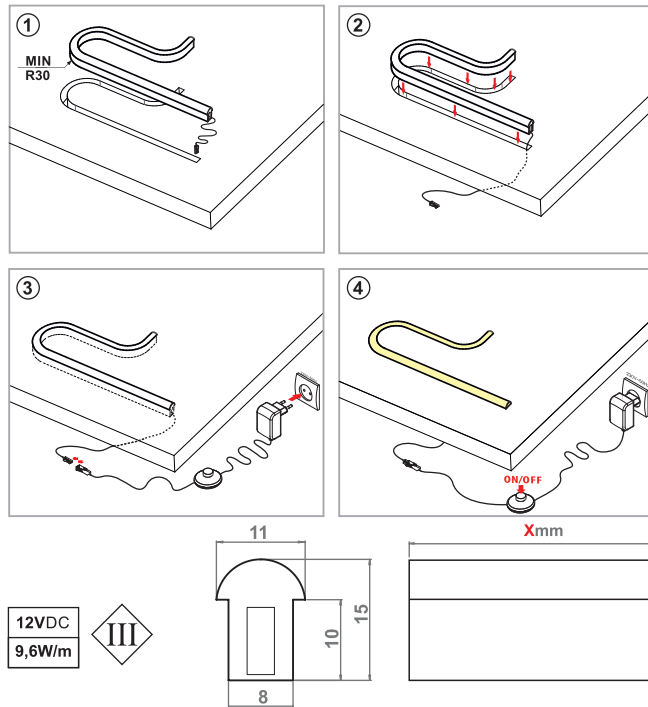

NEON 5x13 FLEX

10.01.89.XY/G/5x13 X: 5 ● Y: 1 ○ 2 ○ 3 ● 4 ● 5 ● 6 ● 8 ○

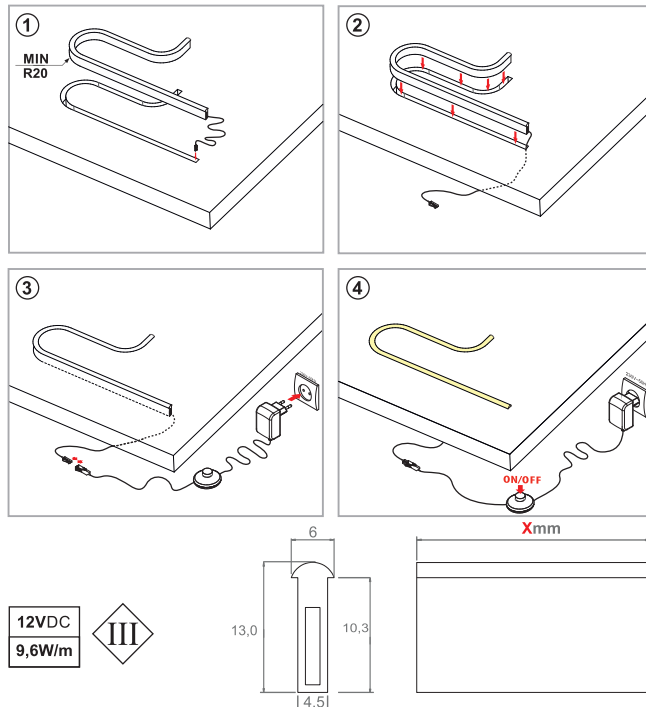

TOUCH SWITCH FP (for PROFIL NEON-5X13-FLEX)

10.07.07.X X: 2 ●

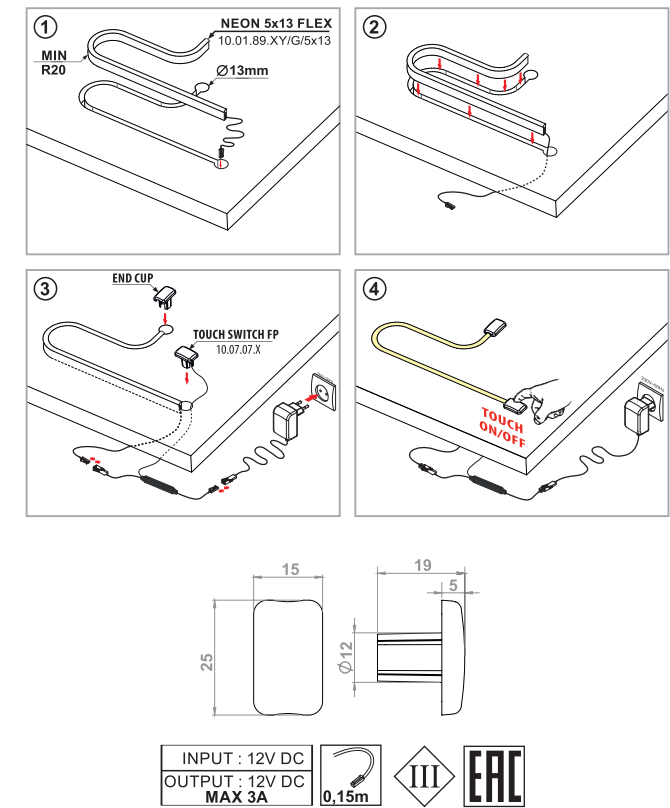
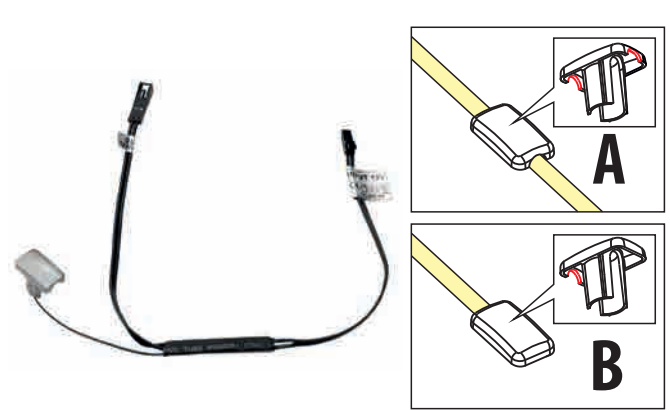

ZETA

10.02.01.XY X: 3 7 Y: 1 2 3 4 5 6 7

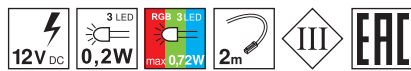
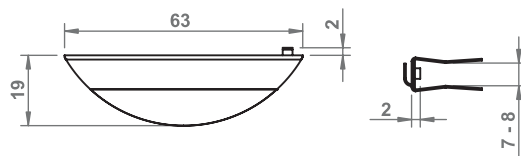
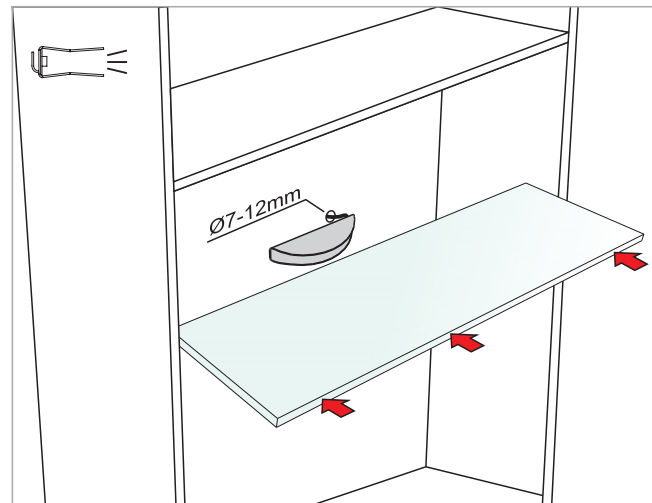

ZETA LINE

10.02.02.XY X: 0 2 5 Y: 1 2 3 4 5 6 7

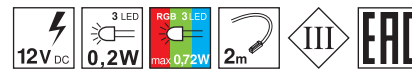
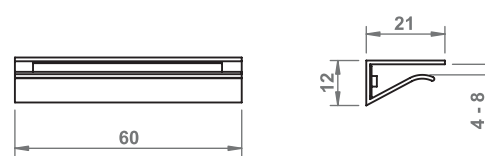
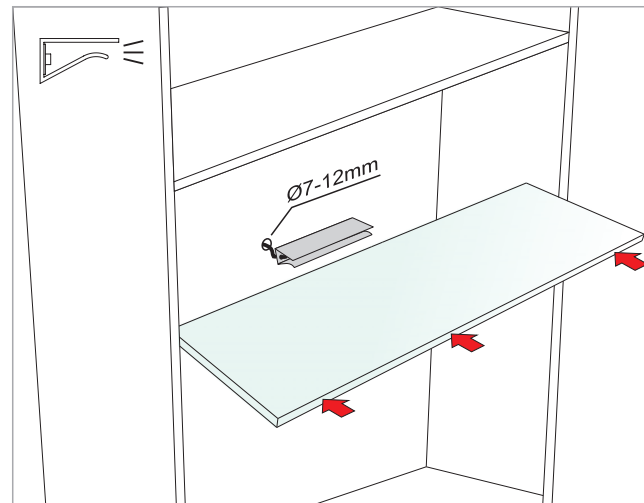

ZETA GLASLINE

10.02.03.XY X: 0 2 5 Y: 1 2 3 4 5 6 7



X mm -Inne długości na zamówienie /
 Xmm -Other lengths on request /
 Xmm-Andere Längen auf Anfrage /
 Xmm-Иная длина по запросу /
 Xmm-长度可根据客户要求

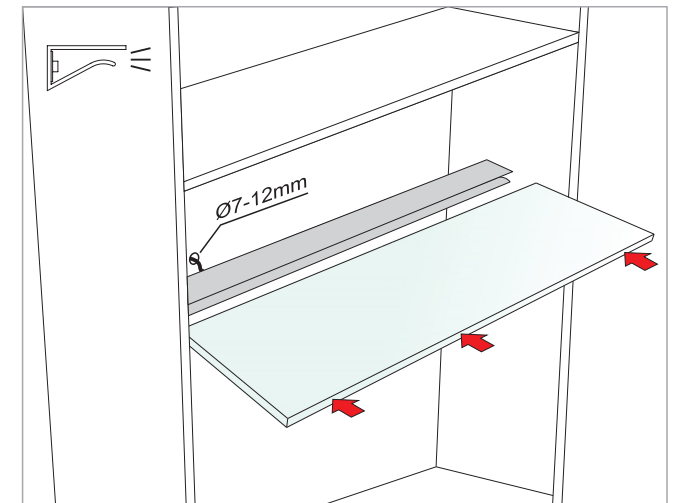

ZETA S 2S

X: 1 ● 2 ○ 4 ○ 8 ● Y: 1 ○ 2 ○ 3 ● 8 ○

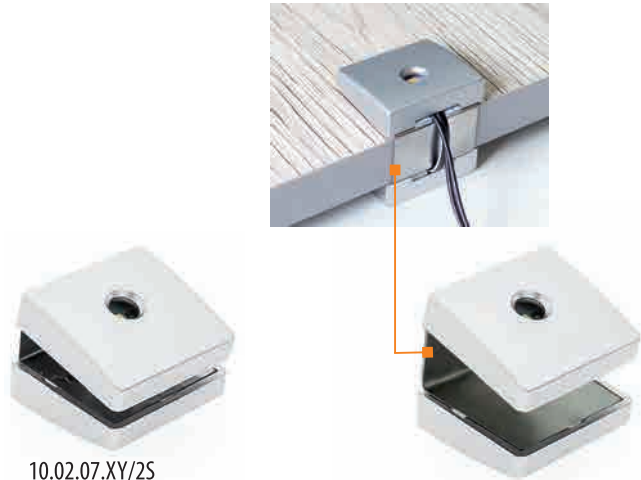

10.02.07.XY/2S

10.02.07.XY/2S - 16mm
10.02.07.XY/2S - 22mm

ZETA S 3S

10.02.07.XY/3S X: 1 ● 2 ○ 4 ○ 8 ● Y: 1 ○ 2 ○ 3 ● 8 ○

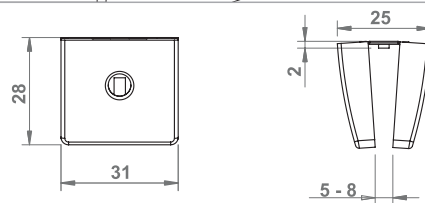
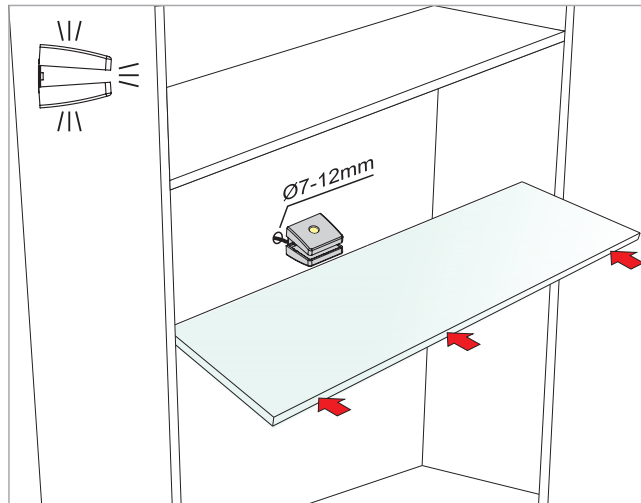

ZETA 3S ZN

10.01.51.XY/3S X: 2 ○ Y: 1 ○ 8 ○ 10.01.51.XY/3S/WM - MASTER

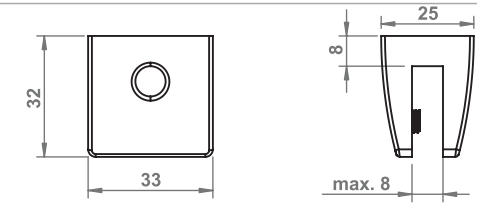
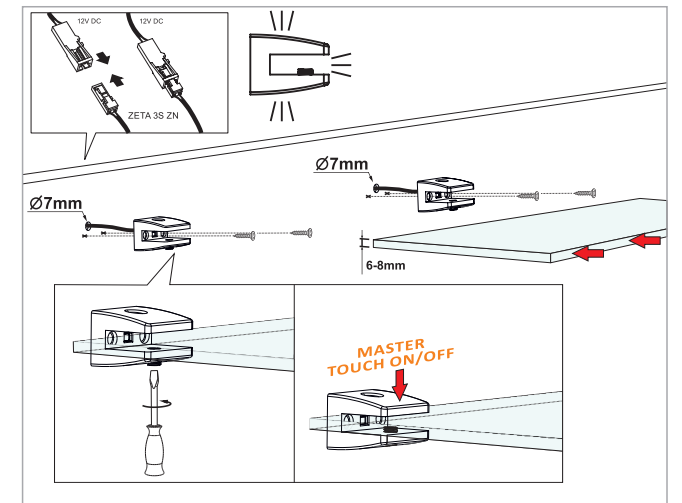
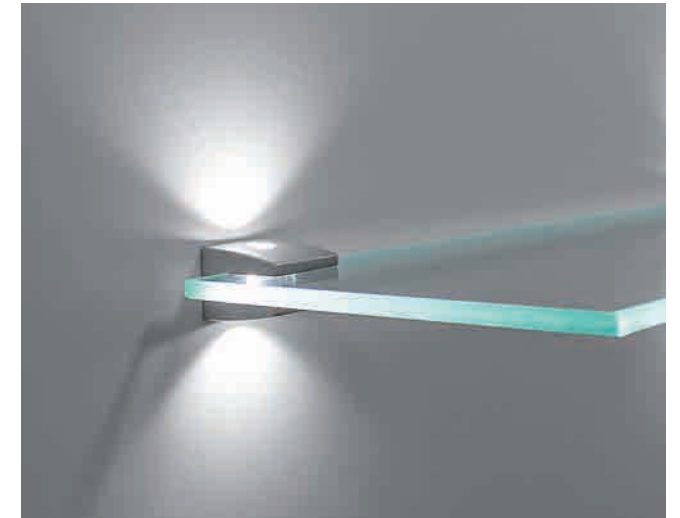

PROFILE DFM

10.01.19.XY X: 2 Y: 1 2 3 4 5 6 7

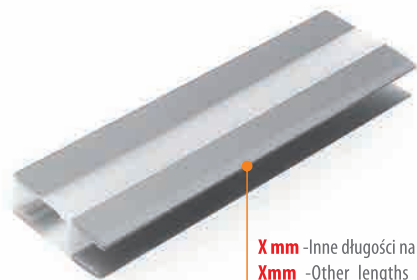

Xmm -Inne długości na zamówienie /
 Xmm -Other lengths on request /
 Xmm -Andere Längen auf Anfrage /
 Xmm -Иная длина по запросу /
 Xmm -长度可根据客户要求

GAMA 2S 60mm

X: 0 2 Y: 1 2 7

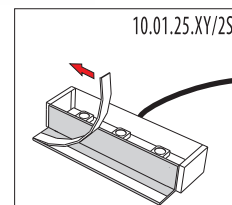

GAMA 3S 60mm

X: 0 2 Y: 1 2 7

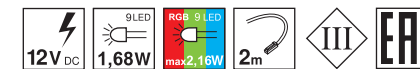
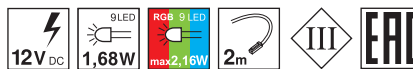
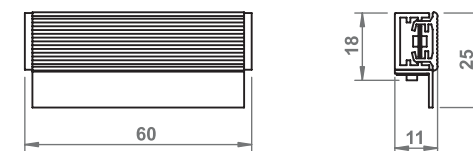
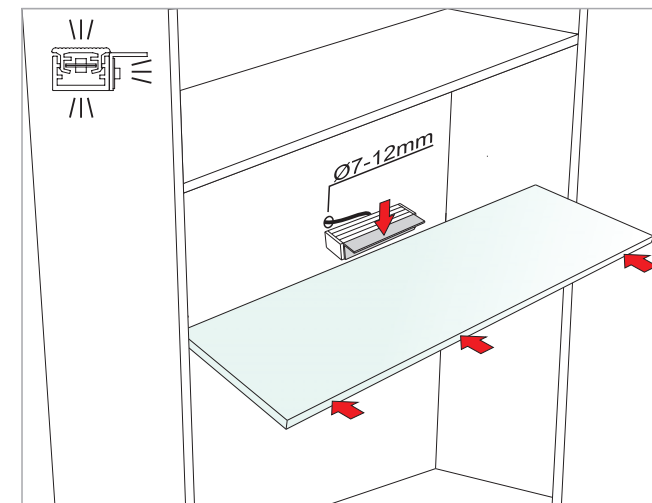
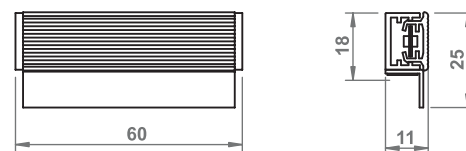
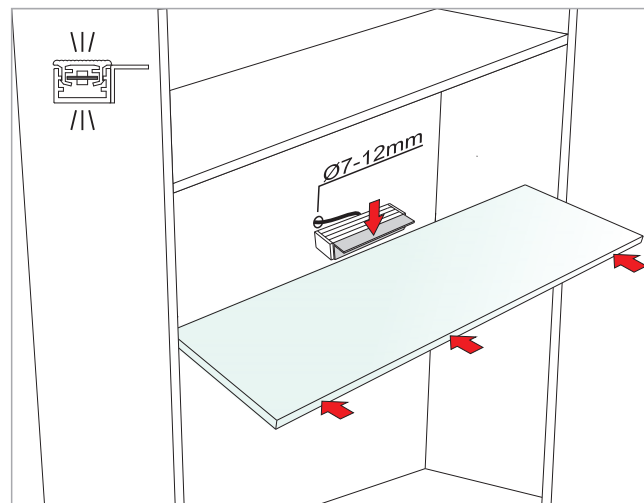
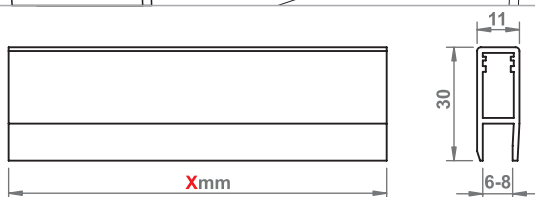
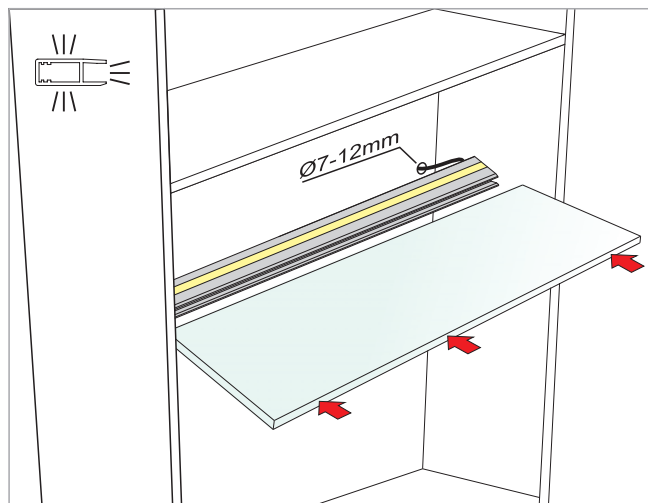
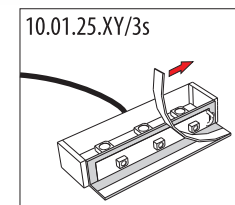

GAMA 2S 300mm

10.01.25.XY/2s/300 X: 0 1 2 Y: 1 2 7

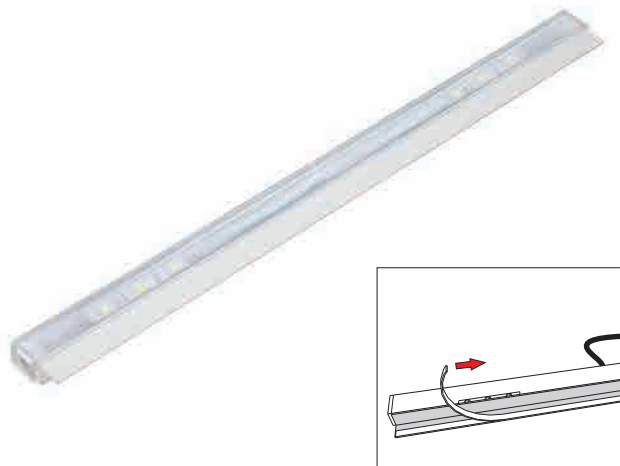

GAMA 3S 300mm

10.01.25.XY/3s/300 X: 0 1 2 Y: 1 2 7

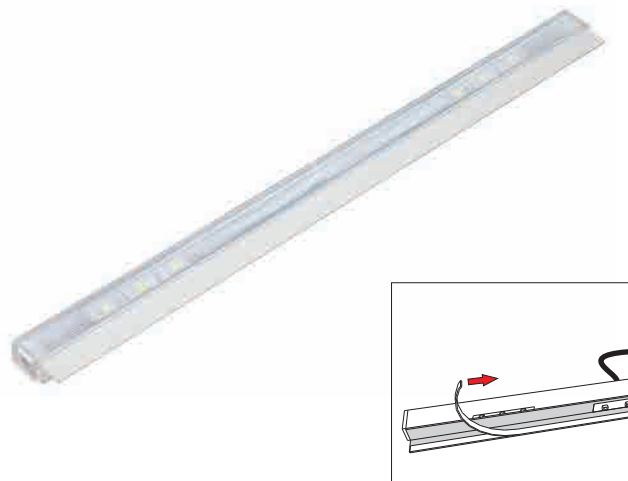

PROFIL TETA

10.01.05.XY X: 0 5 Y: 1 2 3 4 5 6 7



Xmm -Inne długości na zamówienie /
 Xmm -Other lengths on request /
 Xmm -Andere Längen auf Anfrage /
 Xmm -Иная длина по запросу /
 Xmm -长度可根据客户要求

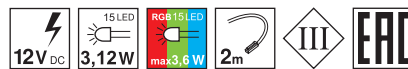
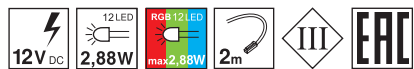
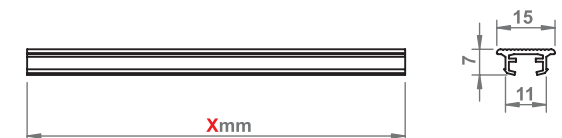
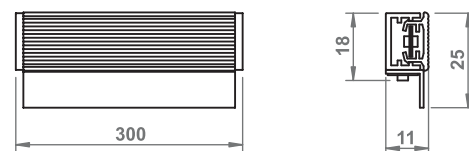
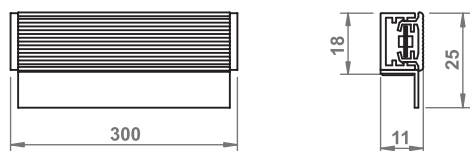
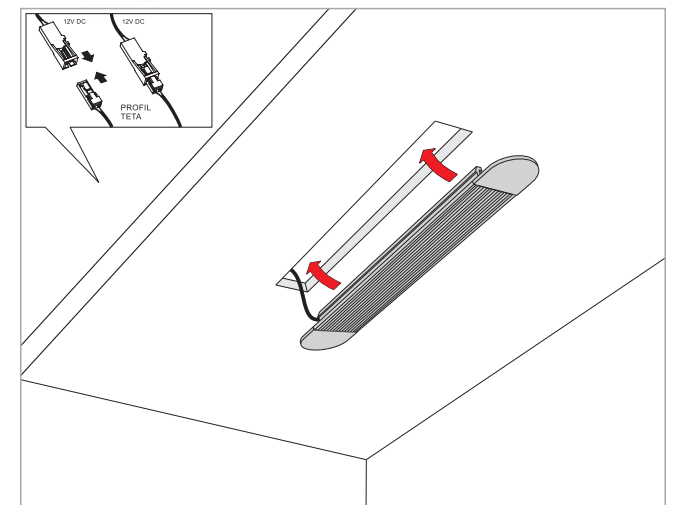
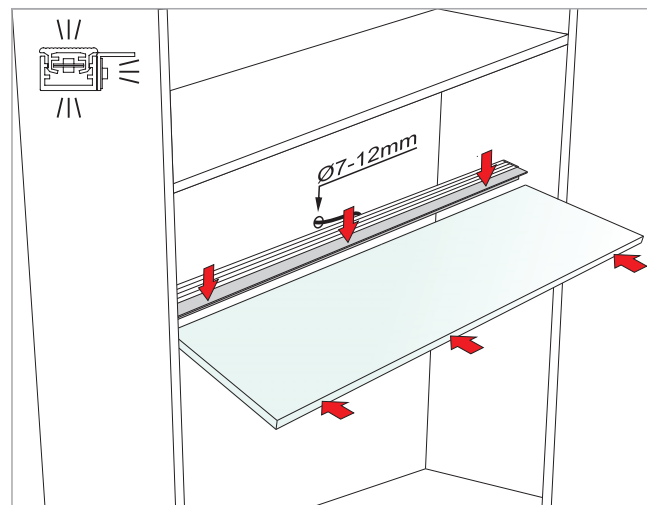
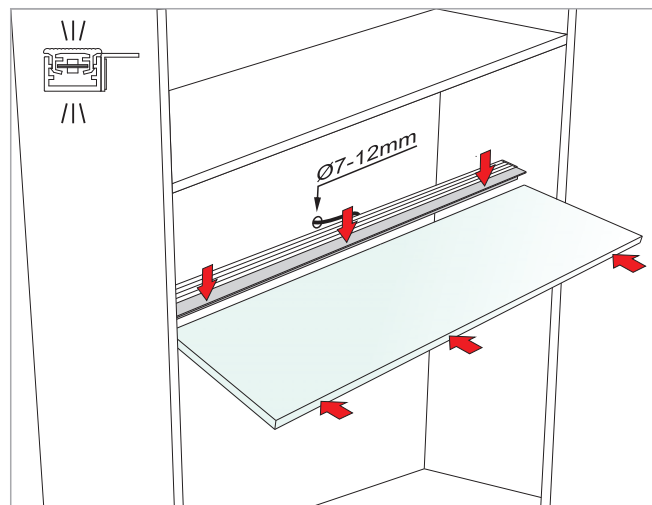

TAU SWITCH

10.01.28.XY/200/W X: 2 Y: 1 /TAU switch /TAU Hauptschalter
/TAU с выкл. Сенсорным

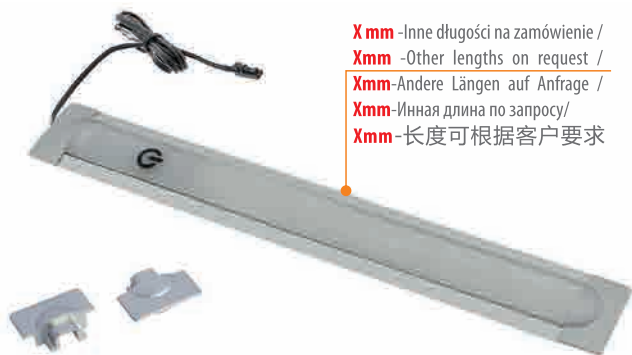

Xmm -Inne długości na zamówienie /
Xmm -Other lengths on request /
Xmm -Andere Längen auf Anfrage /
Xmm -Иная длина по запросу /
Xmm -长度可根据客户要求

TAU

10.01.28.XY X: 2 Y: 1



Xmm -Inne długości na zamówienie /
Xmm -Other lengths on request /
Xmm -Andere Längen auf Anfrage /
Xmm -Иная длина по запросу /
Xmm -长度可根据客户要求

OMEGA 200mm

10.01.26.XY/200 X: 2 Y: 1

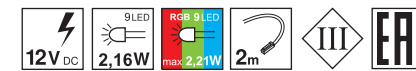
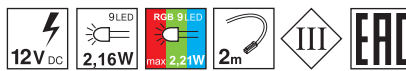
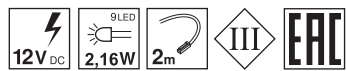
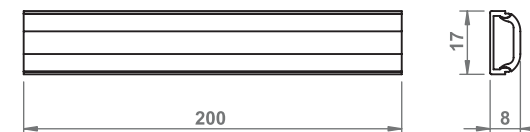
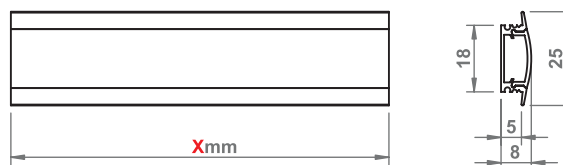
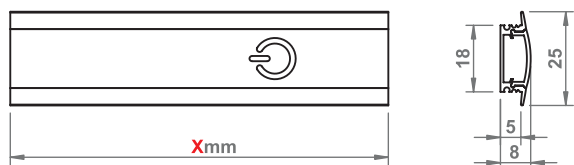
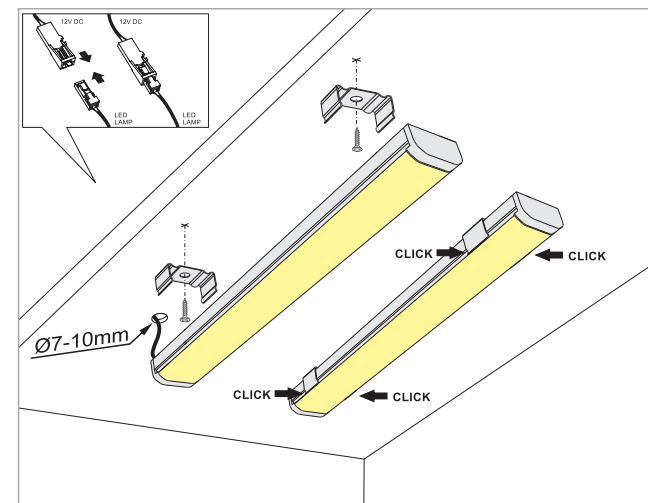
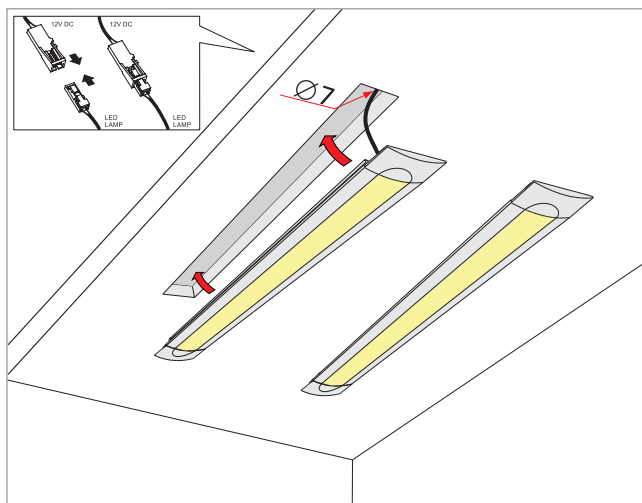
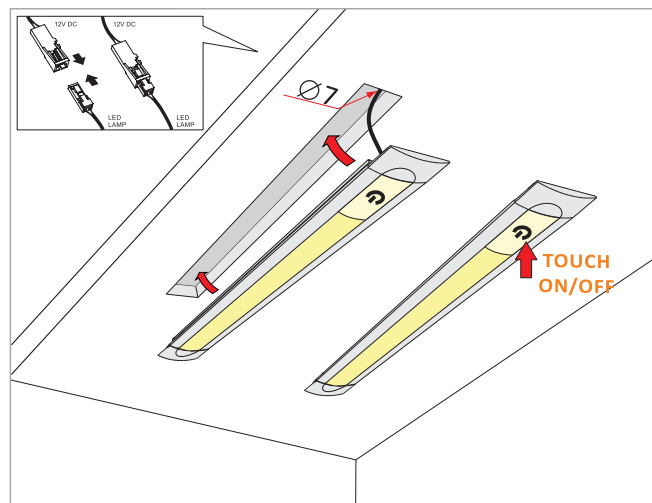

OMEGA SWITCH 200mm

10.01.26.XY/200W X: 2  Y: 1  2  /Omega switch /Omega Hauptschalter / Omega мастер с выключателем/



OMEGA SWITCH MASTER 200mm

10.01.26.XY/200WM X: 2  Y: 1  2  /Omega Master switch /Omega Master mit Schalter / Omega мастер с выключателем/



OMEGA SWITCH

10.01.26.X/W X: 2  /Omega switch /Omega Hauptschalter / Omega выключатель/

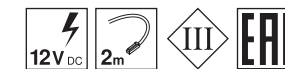
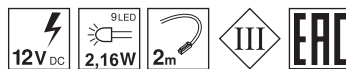
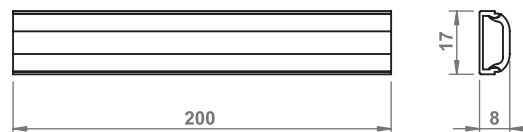
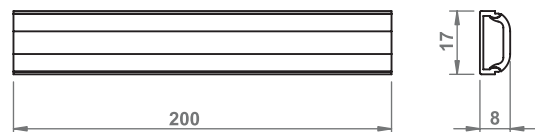
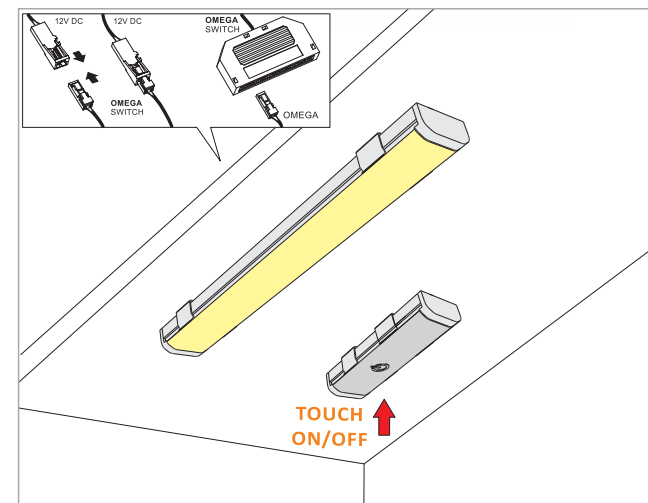
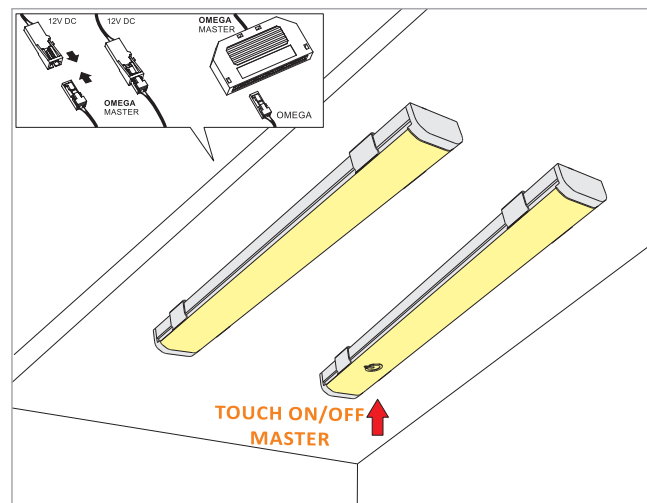
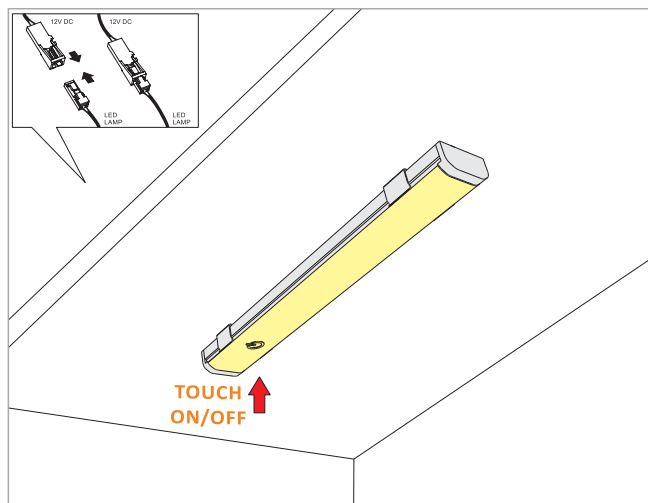

PROFILE OMEGA

10.01.26.XY X: 2 Y: 1 2 3 4 5 6 7



Xmm -Inne długości na zamówienie /
Xmm -Other lengths on request /
Xmm-Andere Längen auf Anfrage /
Xmm-Инная длина по запросу/
Xmm-长度可根据客户要求

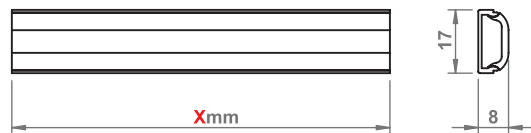
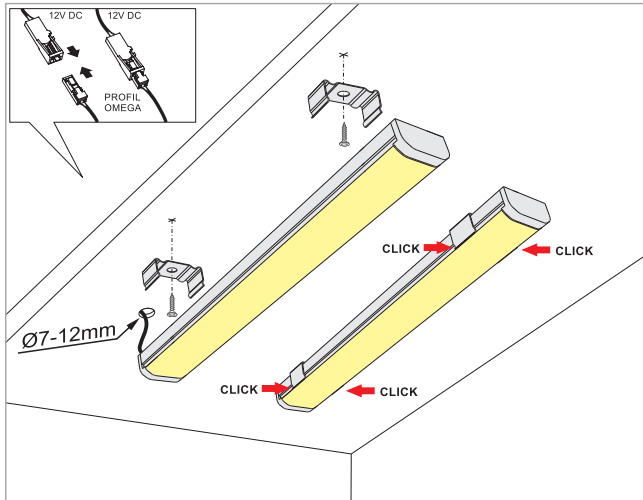

PROFILE LM

10.01.40.XY X: 1 2 4 8 Y: 1 2 3 4 5 6 7



PROFILE LM PIR
10.01.93.XY/PIR

Xmm -Inne długości na zamówienie /
Xmm -Other lengths on request /
Xmm-Andere Längen auf Anfrage /
Xmm-Инная длина по запросу/
Xmm-长度可根据客户要求

PROFILE LM
10.01.40.XY

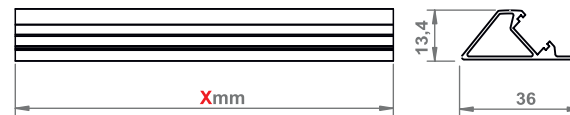
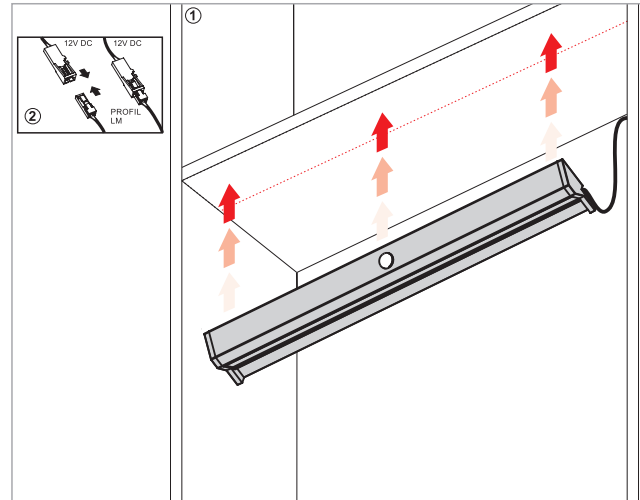

PROFIL MIRROR / IP44

10.01.100.XY X: 2 Y: 1 2 3 4 5 6 7

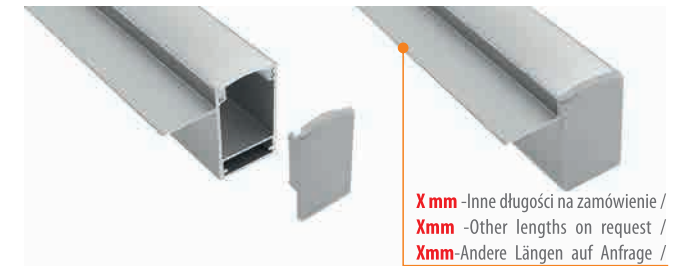

Xmm -Inne długości na zamówienie /
Xmm -Other lengths on request /
Xmm-Andere Längen auf Anfrage /
Xmm-Инная длина по запросу/
Xmm-长度可根据客户要求

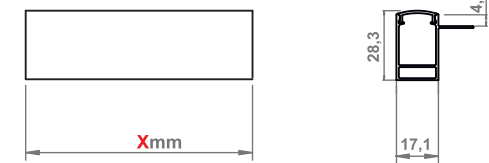
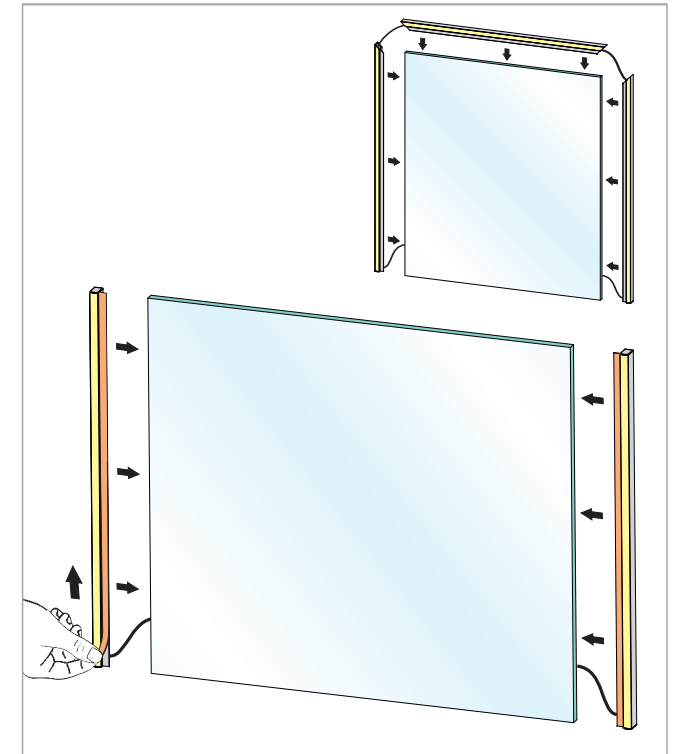

PROFILE LAMBDA / PROFILE LAMBDA mini

X: 2 4 8 Y: 1 2 3 4 5 6 7



Xmm -Inne długości na zamówienie /
Xmm -Other lengths on request /
Xmm-Andere Längen auf Anfrage /
Xmm-Инная длина по запросу/
Xmm -长度可根据客户要求

PROFILE AP

10.01.33.XY Y: 1 2 3 4 5 6 7

Kolory na zamówienie /
Colors on request /
Farben auf Anfrage /
цвета по запросу/

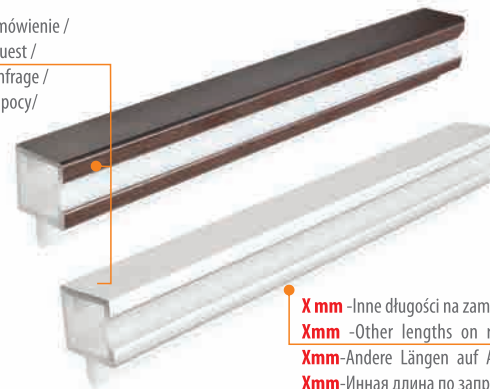

Xmm -Inne długości na zamówienie /
Xmm -Other lengths on request /
Xmm-Andere Längen auf Anfrage /
Xmm-Инная длина по запросу/
Xmm -长度可根据客户要求

PROFILE AP 2H

10.01.33.XY/2H Y: 1 2 3 4 5 6 7

Kolory na zamówienie /
Colors on request /
Farben auf Anfrage /
цвета по запросу/

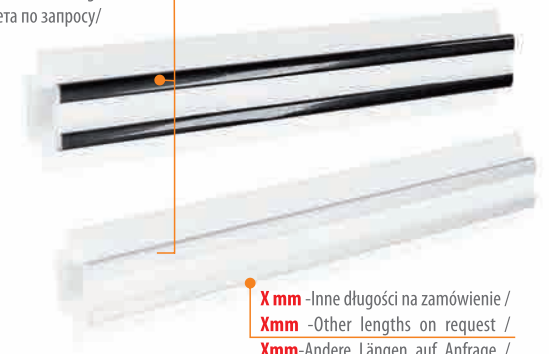

Xmm -Inne długości na zamówienie /
Xmm -Other lengths on request /
Xmm-Andere Längen auf Anfrage /
Xmm-Инная длина по запросу/
Xmm -长度可根据客户要求

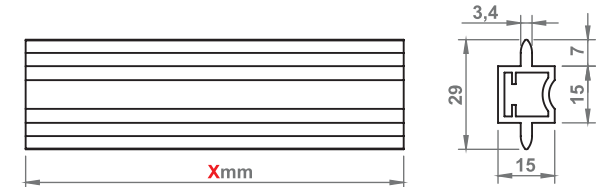
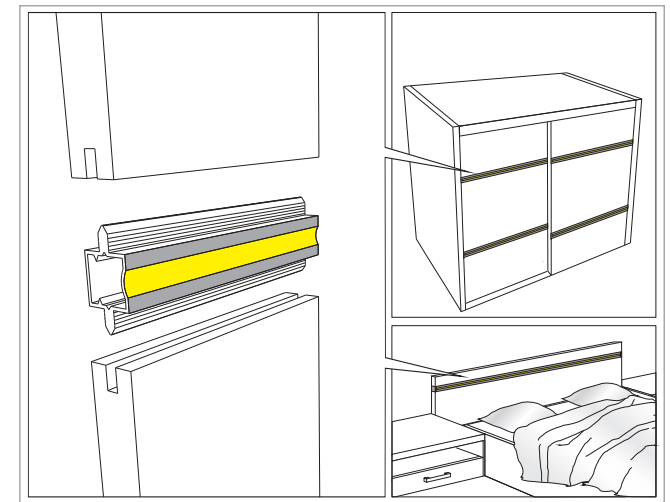
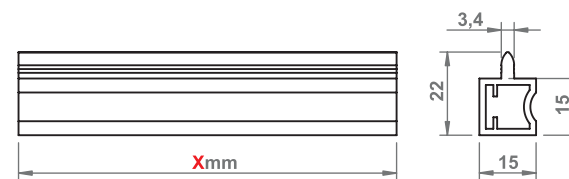
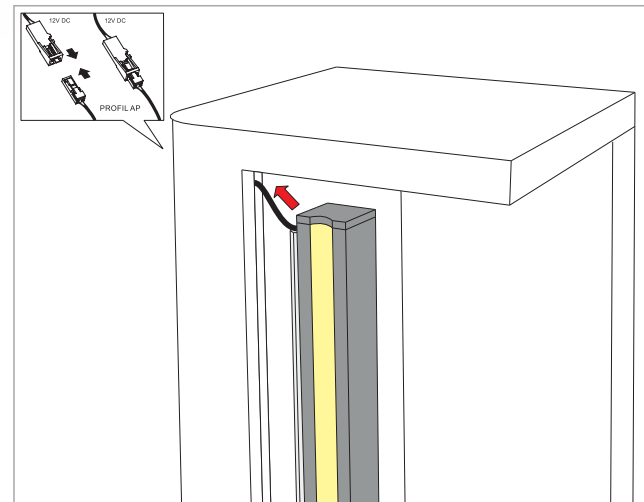
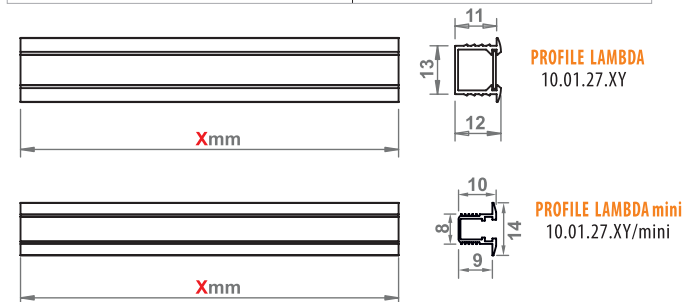
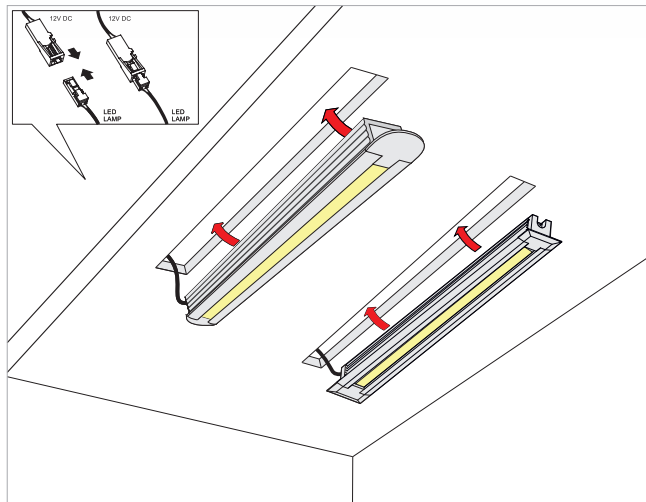

PROFILE KWADRO

10.01.42.XY X: 2 Y: 1 2 3 4 5 6 7



PROFILE RONDO

10.01.41.XY X: 2 Y: 1 2 3 4 5 6 7



PROFILE 5x10

10.01.59.XY X: 5 Y: 1 2 3 4 5 6 7

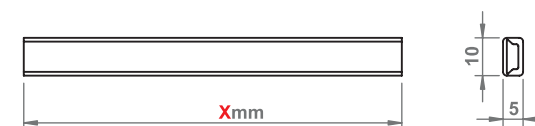
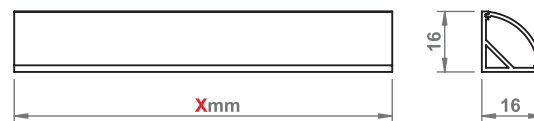
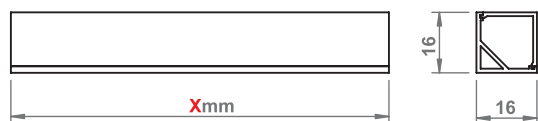
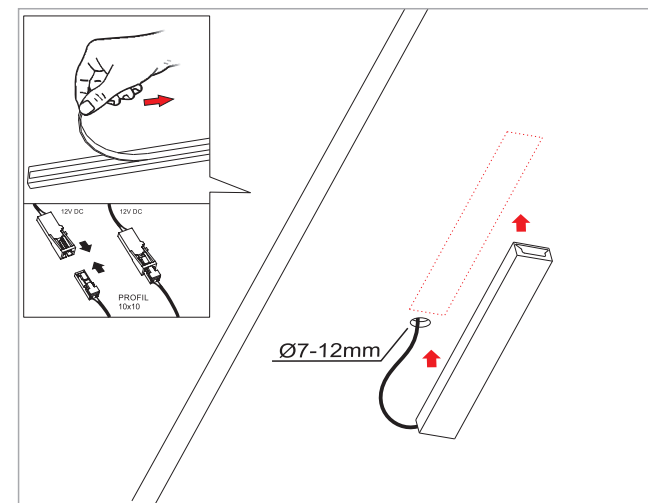
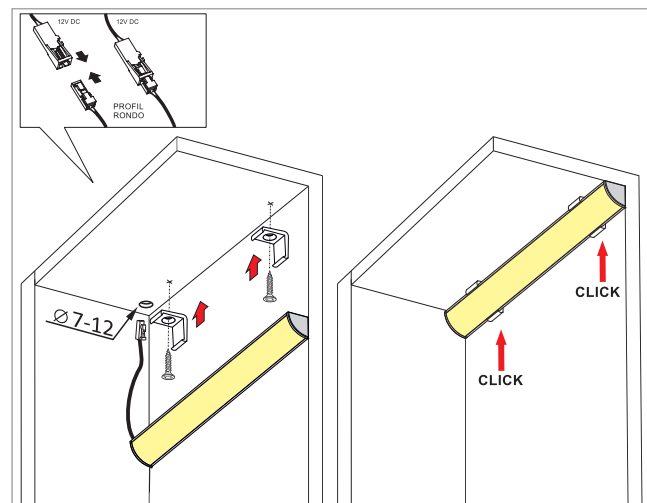
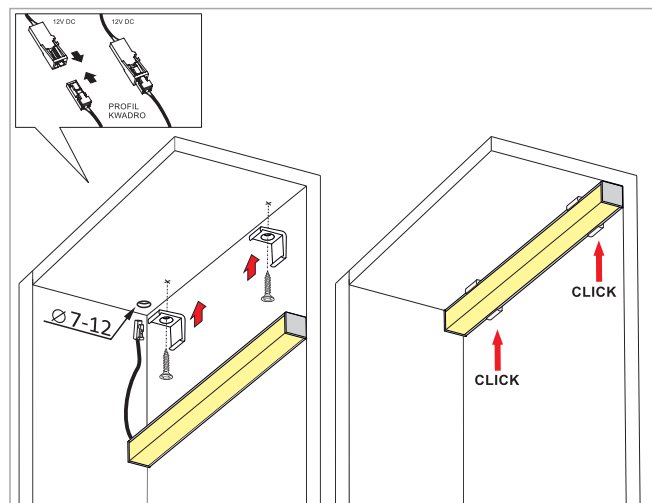

PROFILE 10x10

10.01.34.XY X: 5 Y: 1 0 2 3 4 5 6 7



PROFILE 15x15

10.01.13.XY X: 5 Y: 1 0 2 3 4 5 6 7



PROFILE 15x50

10.01.14.XY X: 5 Y: 1 0 2 3 4 5 6 7

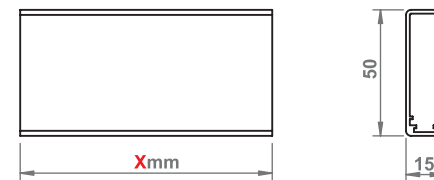
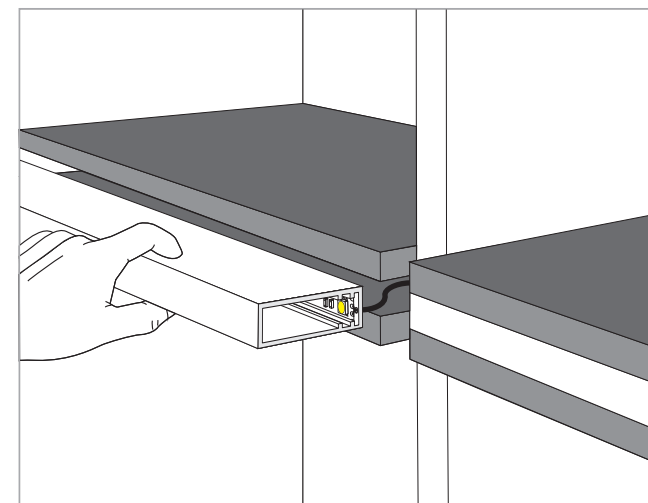
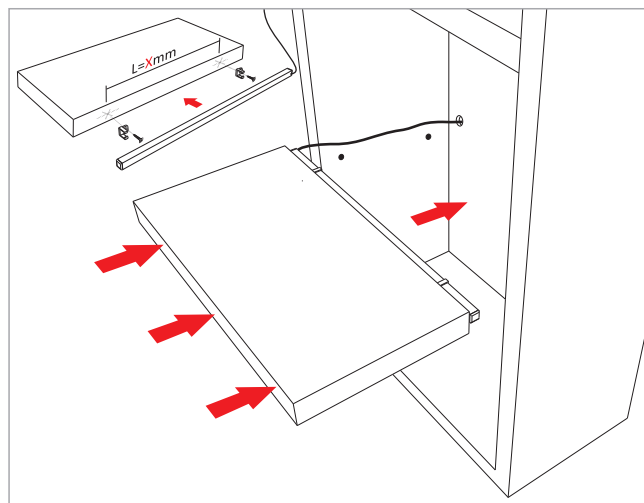
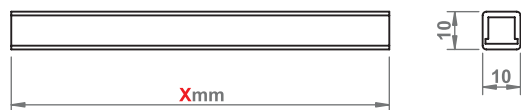
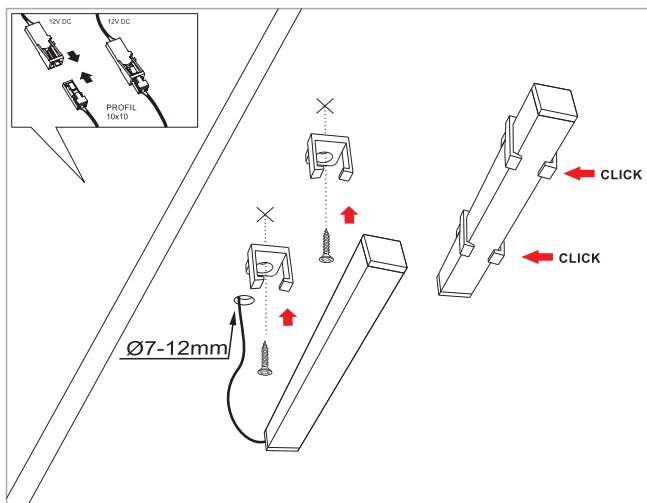

QUAD-C

10.01.133.XY X: 2 4 8 Y: 1 2 8

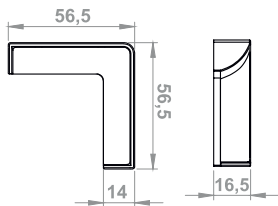
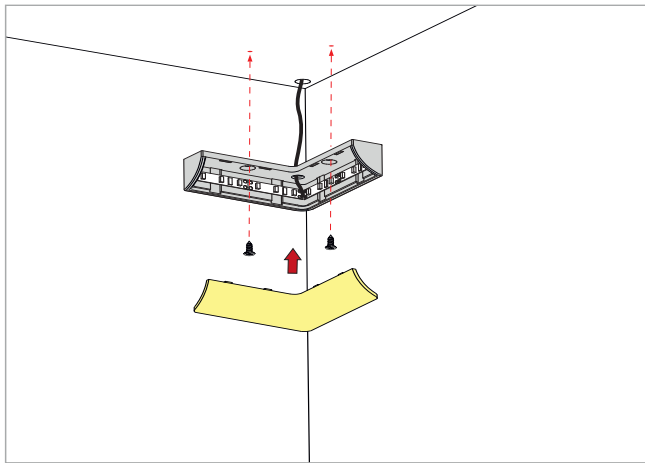
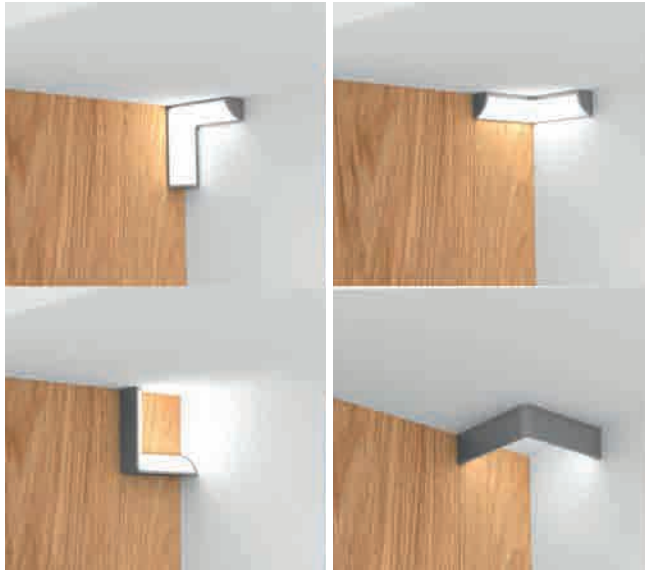

PROFILE PI 29x15

10.01.81.XY/29x15 X: 5 Y: 1 2 3 4 5 6 7



Xmm -Inne długości na zamówienie /
 Xmm -Other lengths on request /
 Xmm -Andere Längen auf Anfrage /
 Xmm -Иная длина по запросу /
 Xmm -长度可根据客户要求

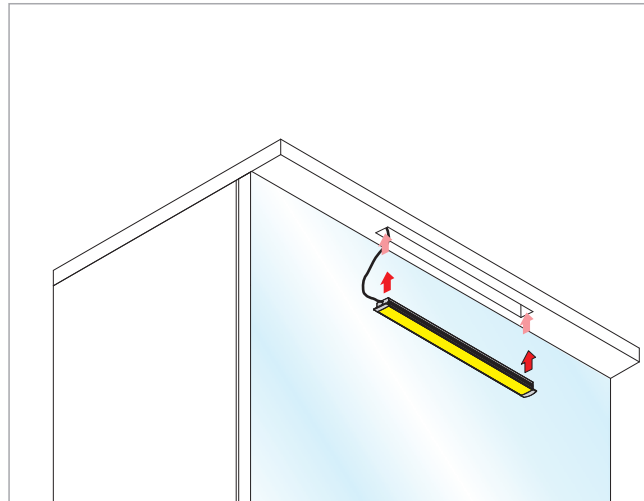

PROFILE XI 16x7

10.01.82.XY X: 2 Y: 1 2 3 4 5 6 7



Xmm -Inne długości na zamówienie /
 Xmm -Other lengths on request /
 Xmm -Andere Längen auf Anfrage /
 Xmm -Иная длина по запросу /
 Xmm -长度可根据客户要求

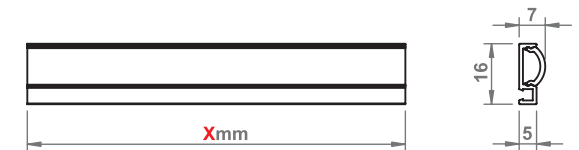
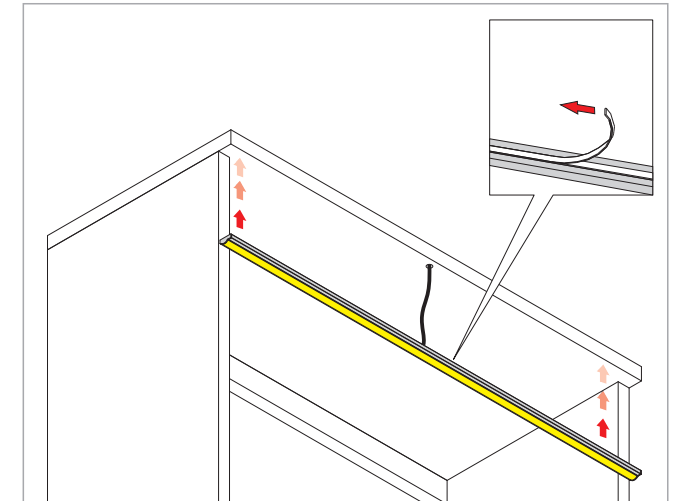

PROFIL D 15x27

10.01.66.XY/D X: 2 Y: 1 2 3 4 5 6 7



1A-12W

Xmm -Inne długości na zamówienie /
 Xmm -Other lengths on request /
 Xmm-Andere Längen auf Anfrage /
 Xmm-Инная длина по запросу/
 Xmm-长度可根据客户要求



PROFILE GAMA

10.01.06.XY X: 2 5 Y: 1 2 3 4 5 6 7



Xmm -Inne długości na zamówienie /
 Xmm -Other lengths on request /
 Xmm-Andere Längen auf Anfrage /
 Xmm-Инная длина по запросу/
 Xmm-长度可根据客户要求

PROFILE 10x20

10.01.124.XY X: 5 Y: 1 2 3 4 5 6 7

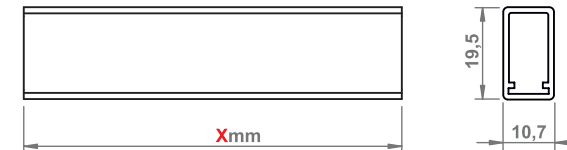
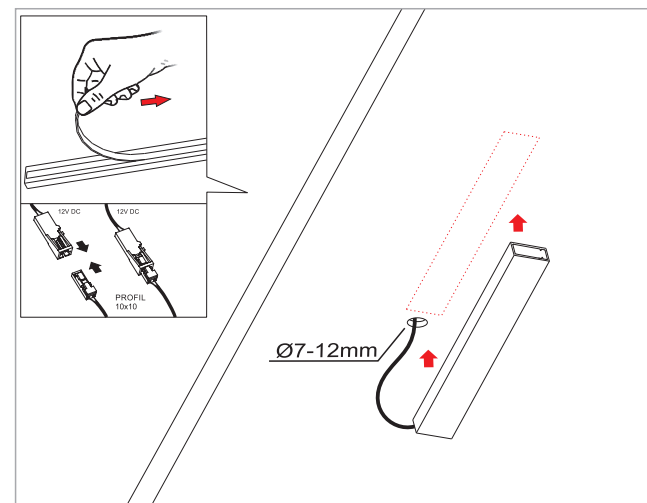
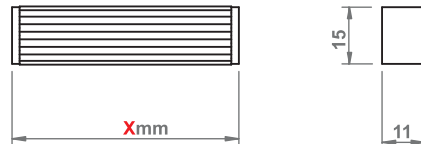
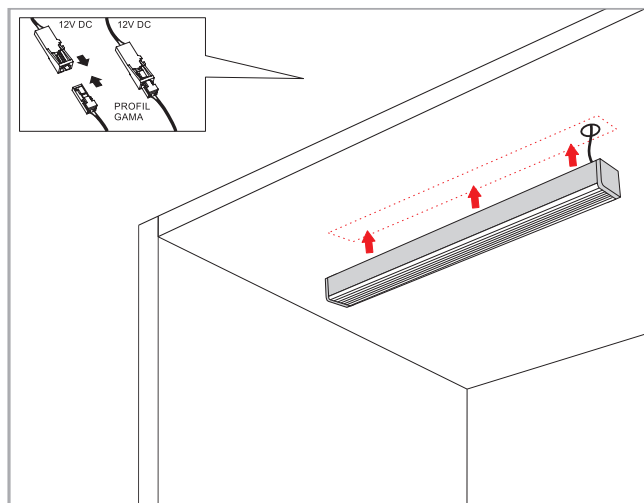
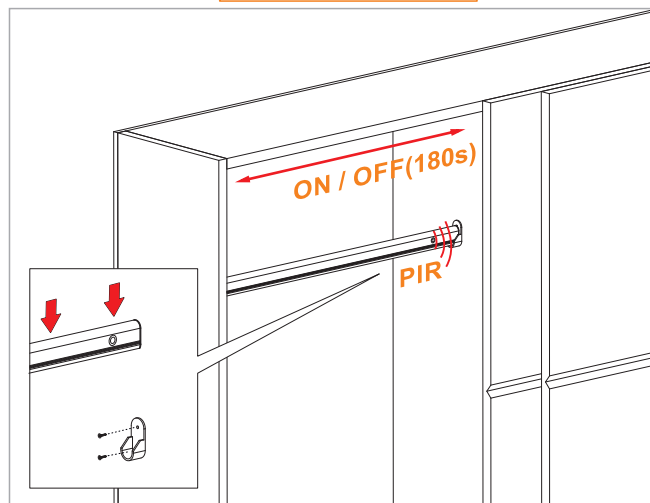

RONDO D

10.01.62.XY/D X: 2 3 4 5 6 7 Y: 1 2 3 4 5 6 7



RONDO S

10.01.61.XY/S X: 2 3 4 5 6 Y: 1 2 3 4 5 6 7

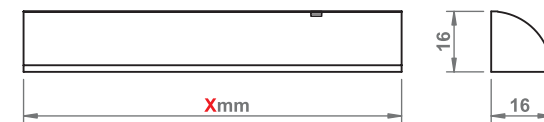
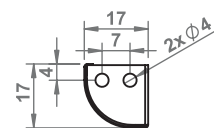
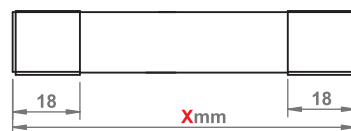
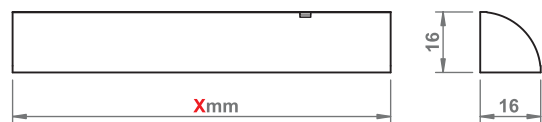
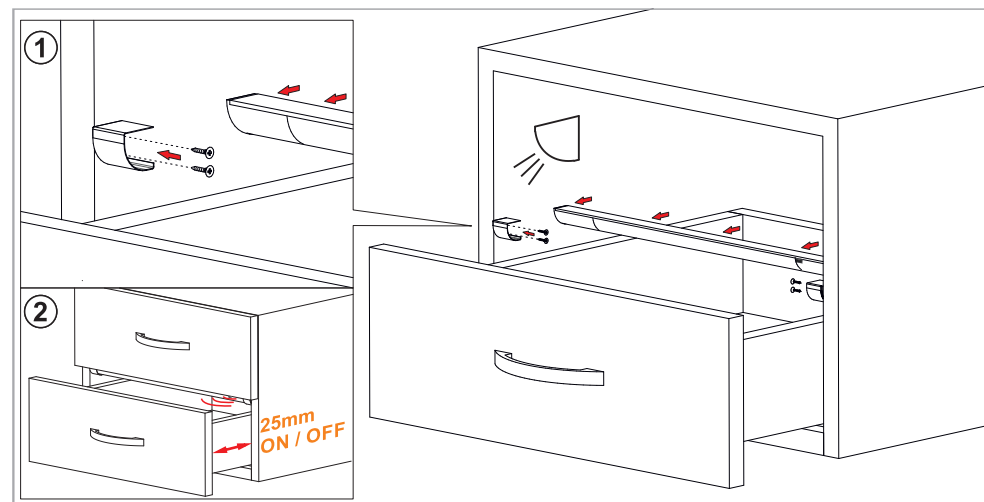
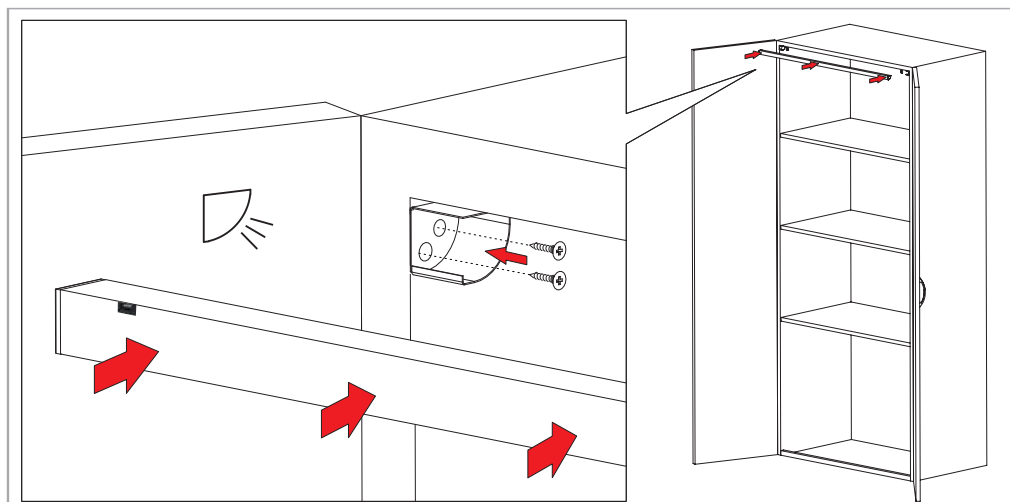
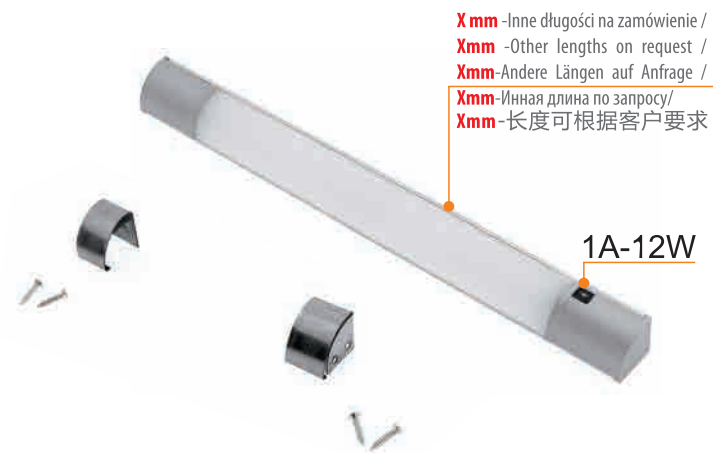

BULB (MIRROR LAMP)

10.01.143.XY X: 4 Y: 8

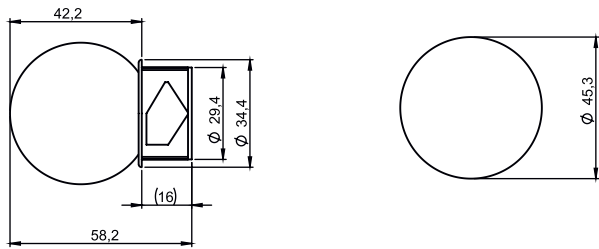
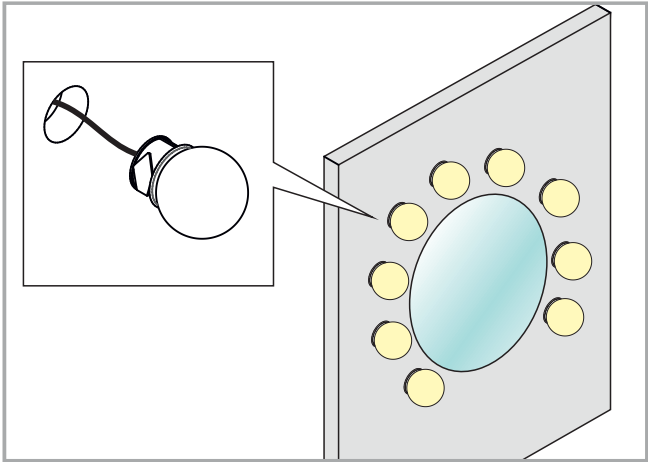
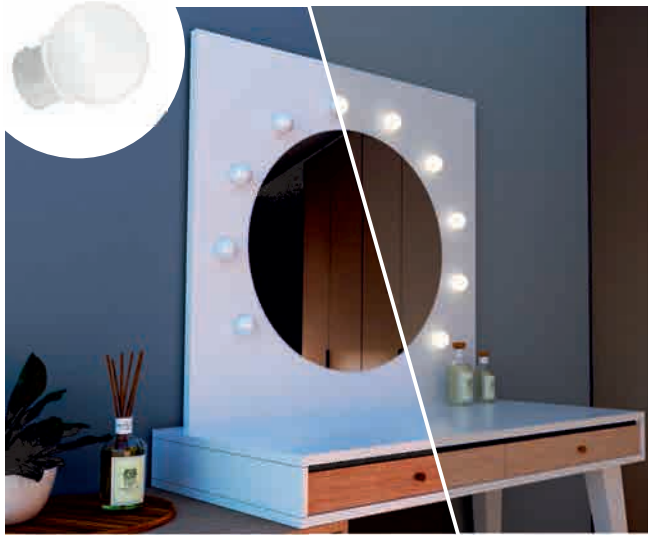

POLA S

10.01.97.XY X: 1 Y: 1 8

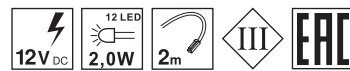
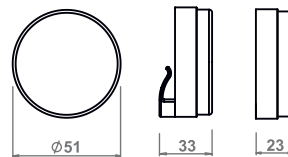
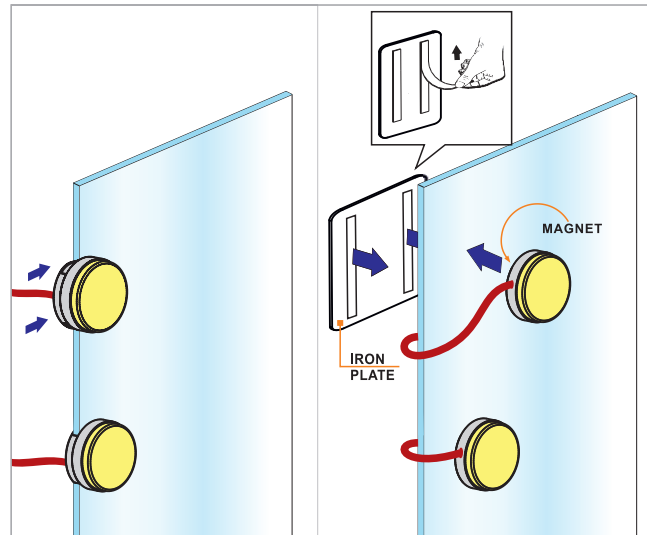
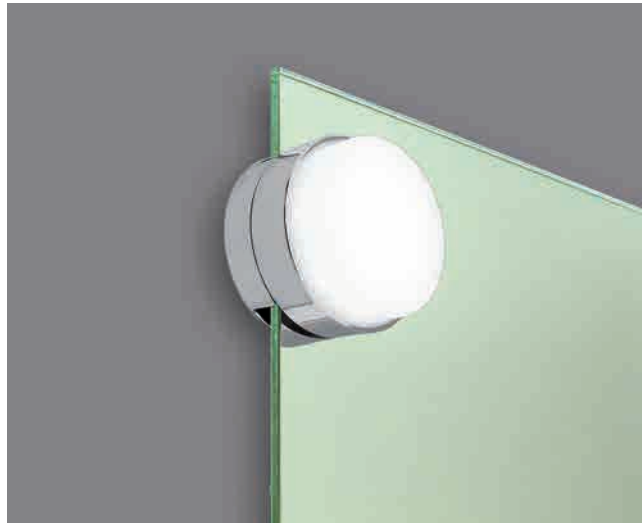

POLA M

10.01.98.XY X: 1 Y: 1 8

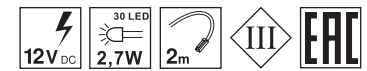
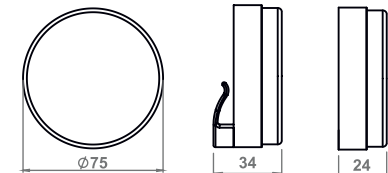
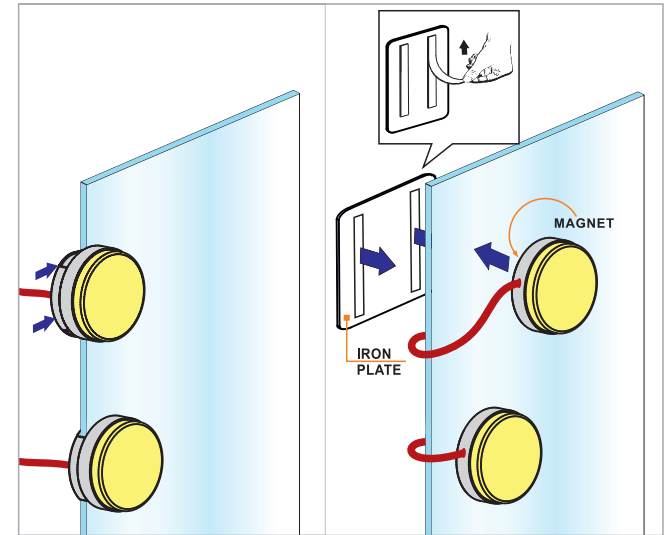

TOUCH SWITCH FOR MIRROR

Touch switch for mirror /Berührungsschalter für Spiegel/ выключатель э/м для зеркала

10.05.09/CW Y:1○/1○ | ON/OFF

10.05.09/CW/DIM Y:1○/1○ | ○ | ON/OFF

10.05.09 Y:3●/4● | ON/OFF

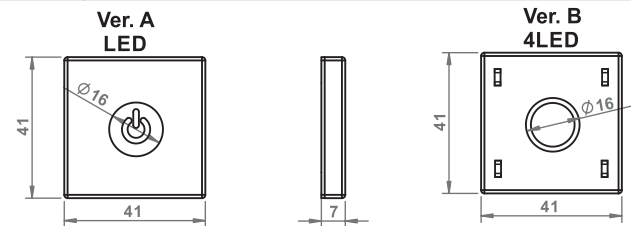
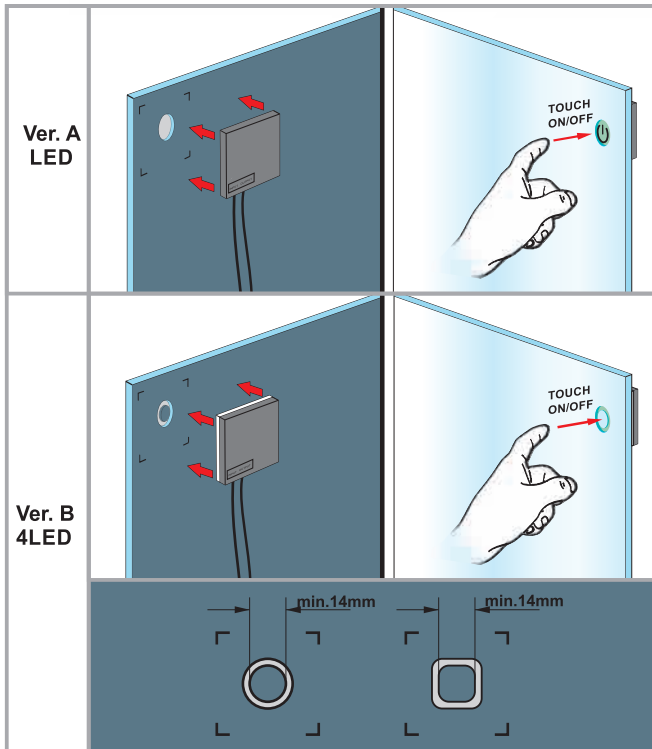

TOUCH SWITCH FOR CHIPBOARD

10.05.10 /Touch dimmable switch for chipboard 10-25/Berührungsschalter für Holz 10-25 /

выключатель э/м для плит 10-25

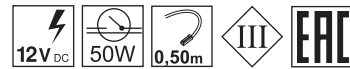
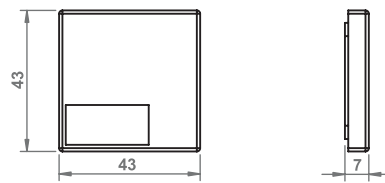
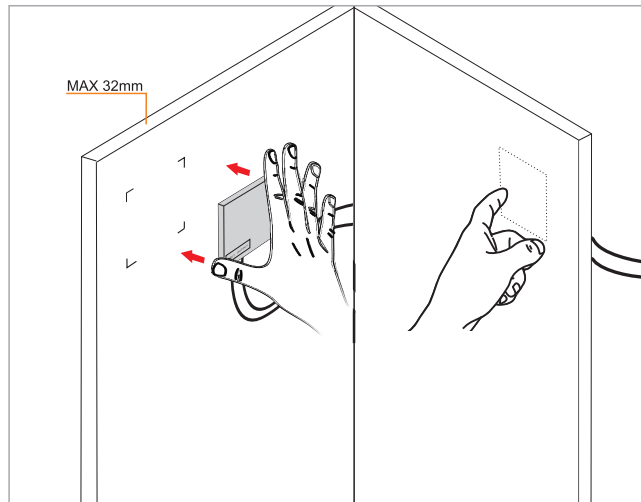

SWITCH STICK

10.04.15.X X: 8●4○

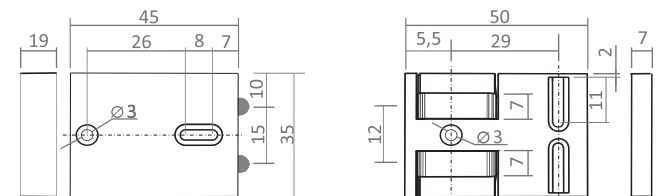
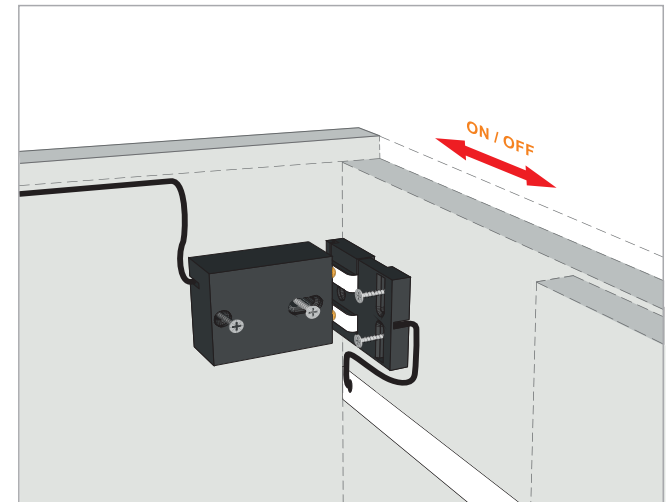

SWITCH MINI

20.04.02.X/mini X: 4  8  /switch mini furniture/ Möbel Minischalter/
переключения мини мебели



SWITCH / SWITCH /IP44

/Switch/ Schalter/ выключатель

20.04.02



20.04.02/IP44

F22 SWITCH (12V)

10.05.14/12V /Switch/ Schalter/ выключатель

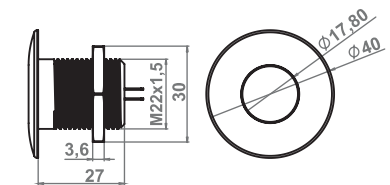
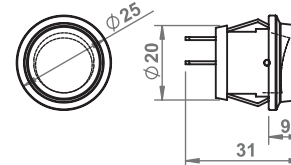
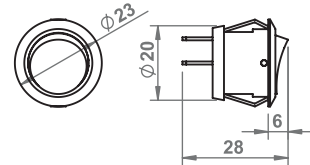
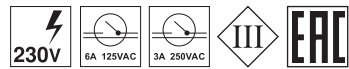
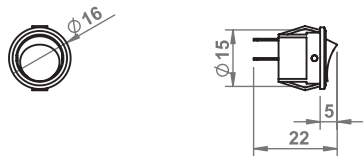
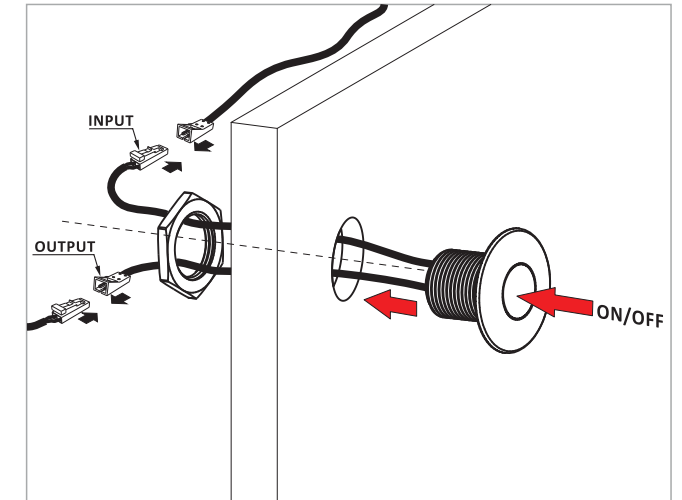
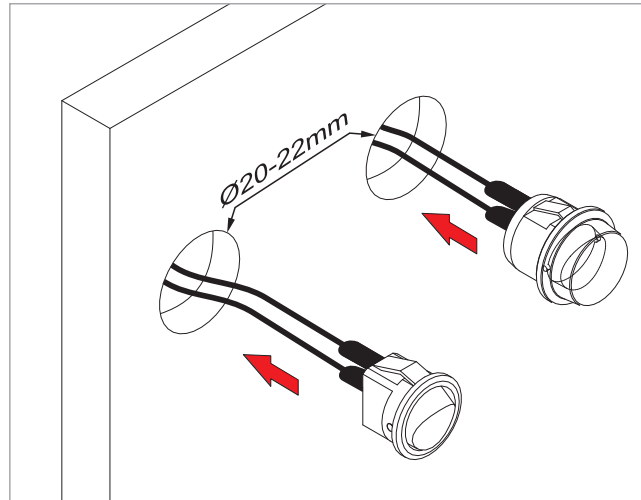
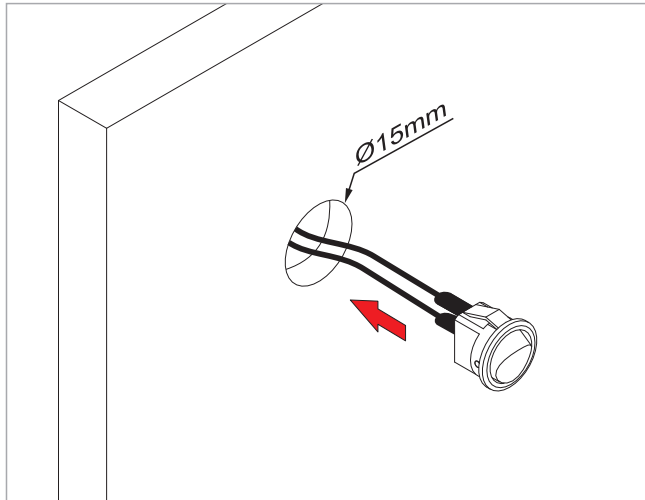

SWITCH FOR DOOR

10.05.11/D /switch for door / Schalter für Türe/ выключатель для передвижных дверей



SWITCH FOR MOVEMENT

10.05.11/M /switch for door / Schalter für Türe/ выключатель для передвижных дверей



SWITCH PIR

10.05.11/PIR /switch PIR / Schalter PIR/ выключатель PIR

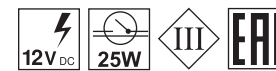
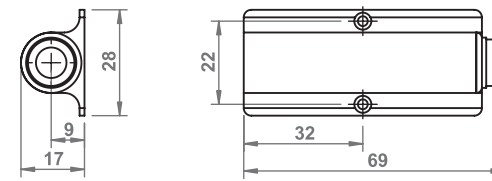
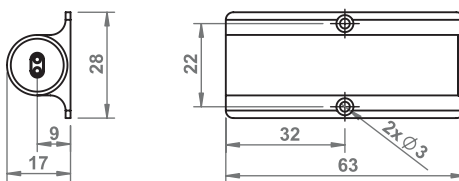
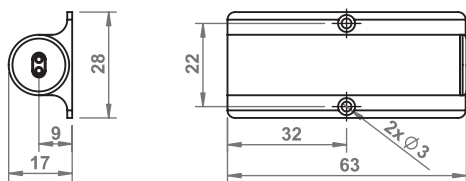
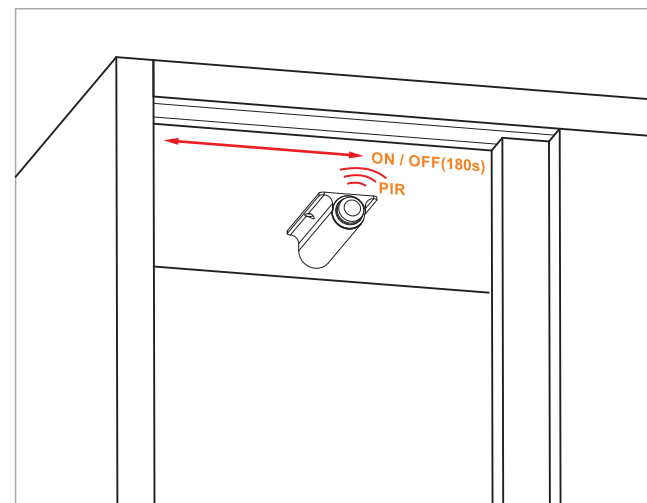
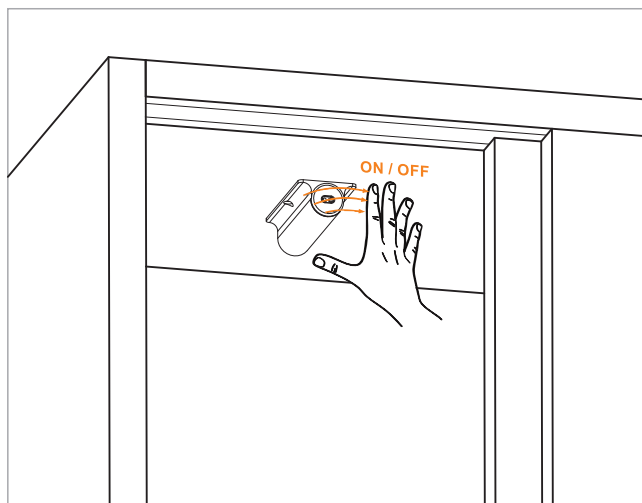
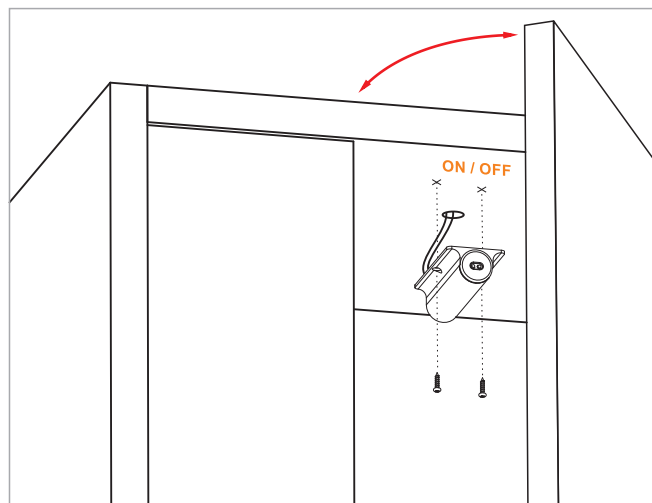

BED SWITCH M

10.05.16.X/M X: 2 4 8

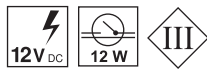
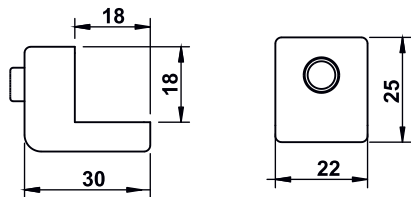
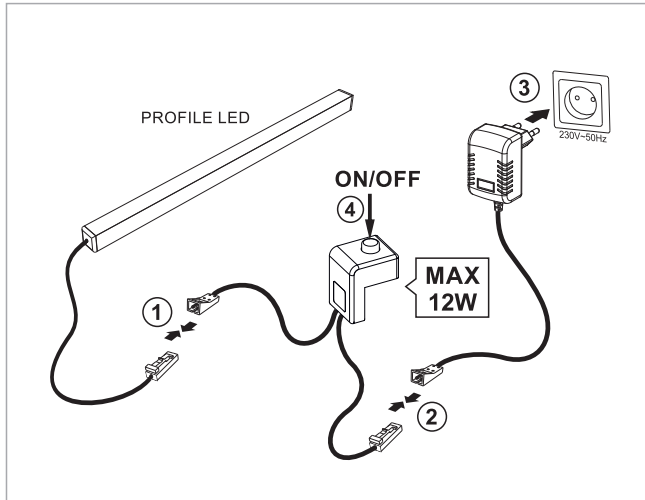

BED SWITCH L

10.05.16.X/L X: 2 4 8
10.05.16.X/L/LED X: 2 4 8

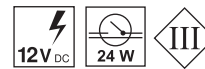
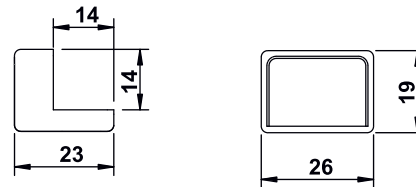
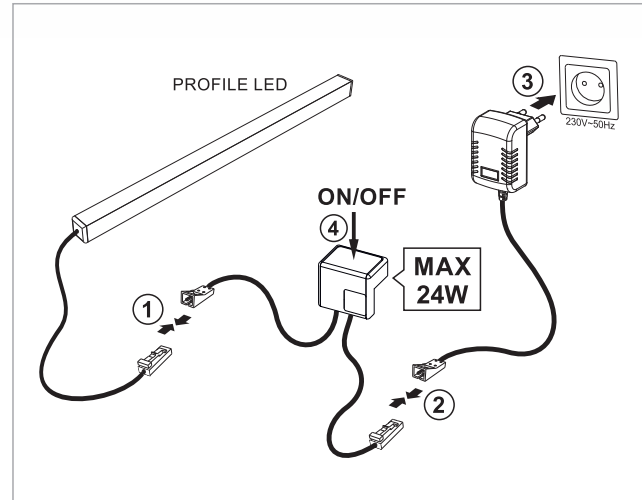
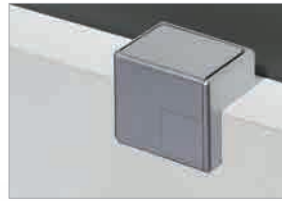

BED SWITCH DUO

10.05.16.X/DUO X: 2 4 8
10.05.16.X/DUO/DIM X: 2 4 8

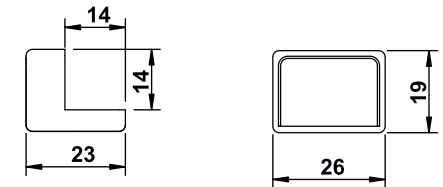
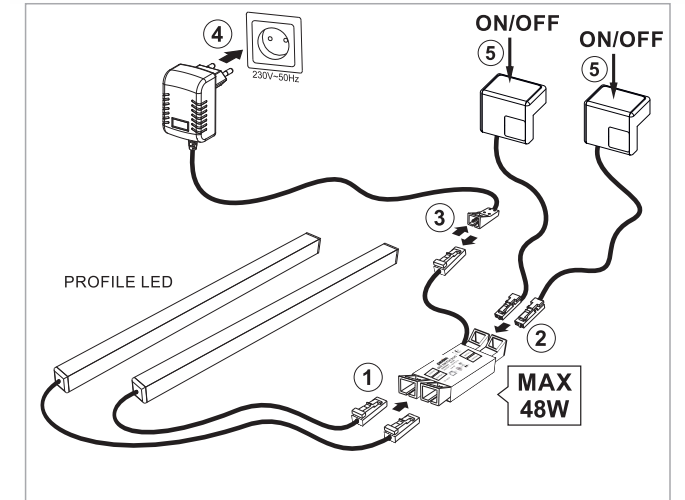
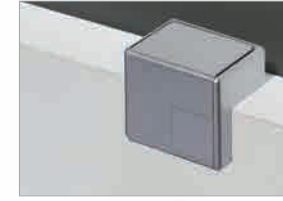

DUO SWITCH NORMAL

10.07.08/NORMAL

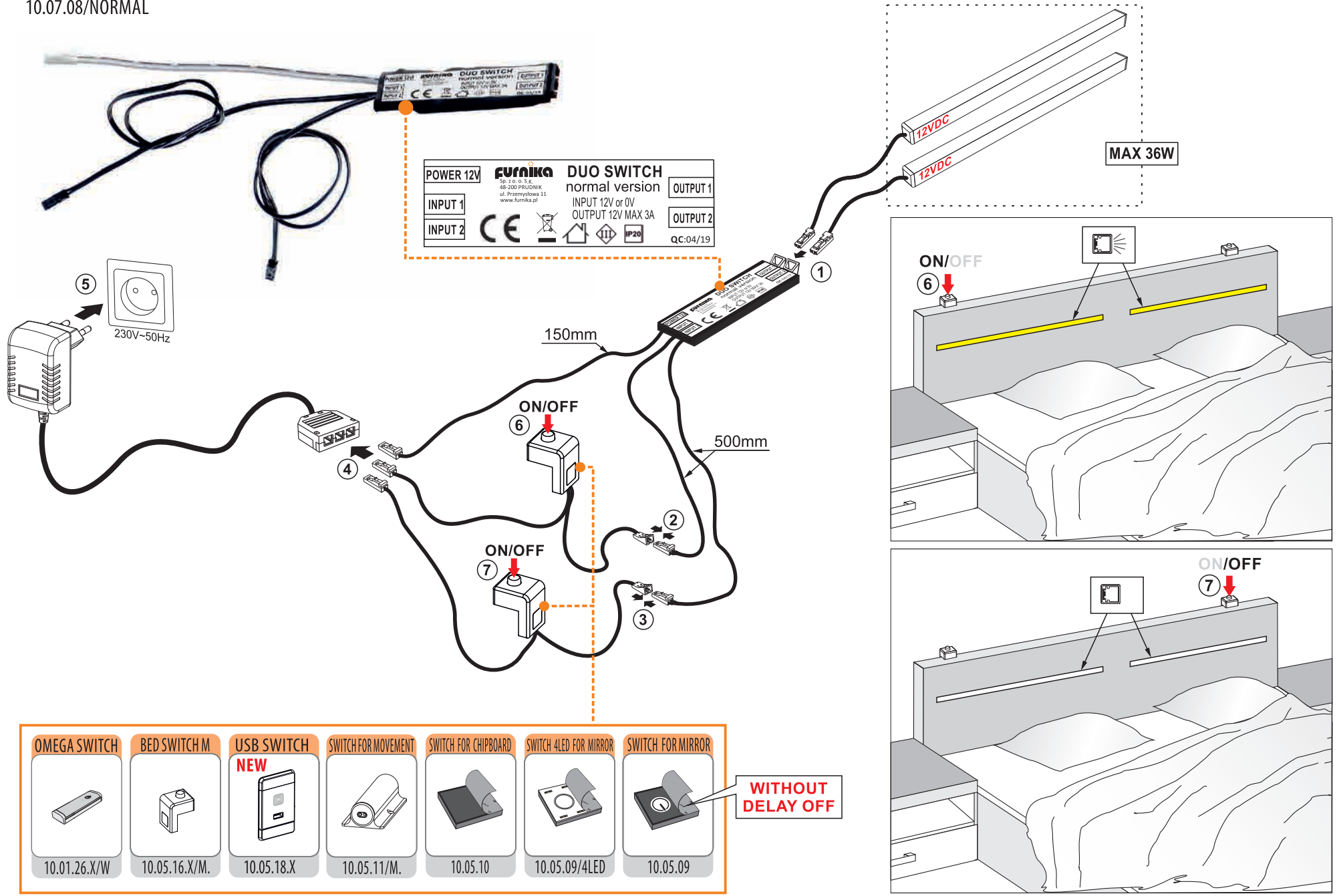

DUO SWITCH PIR

10.07.08/PIR/DOOR

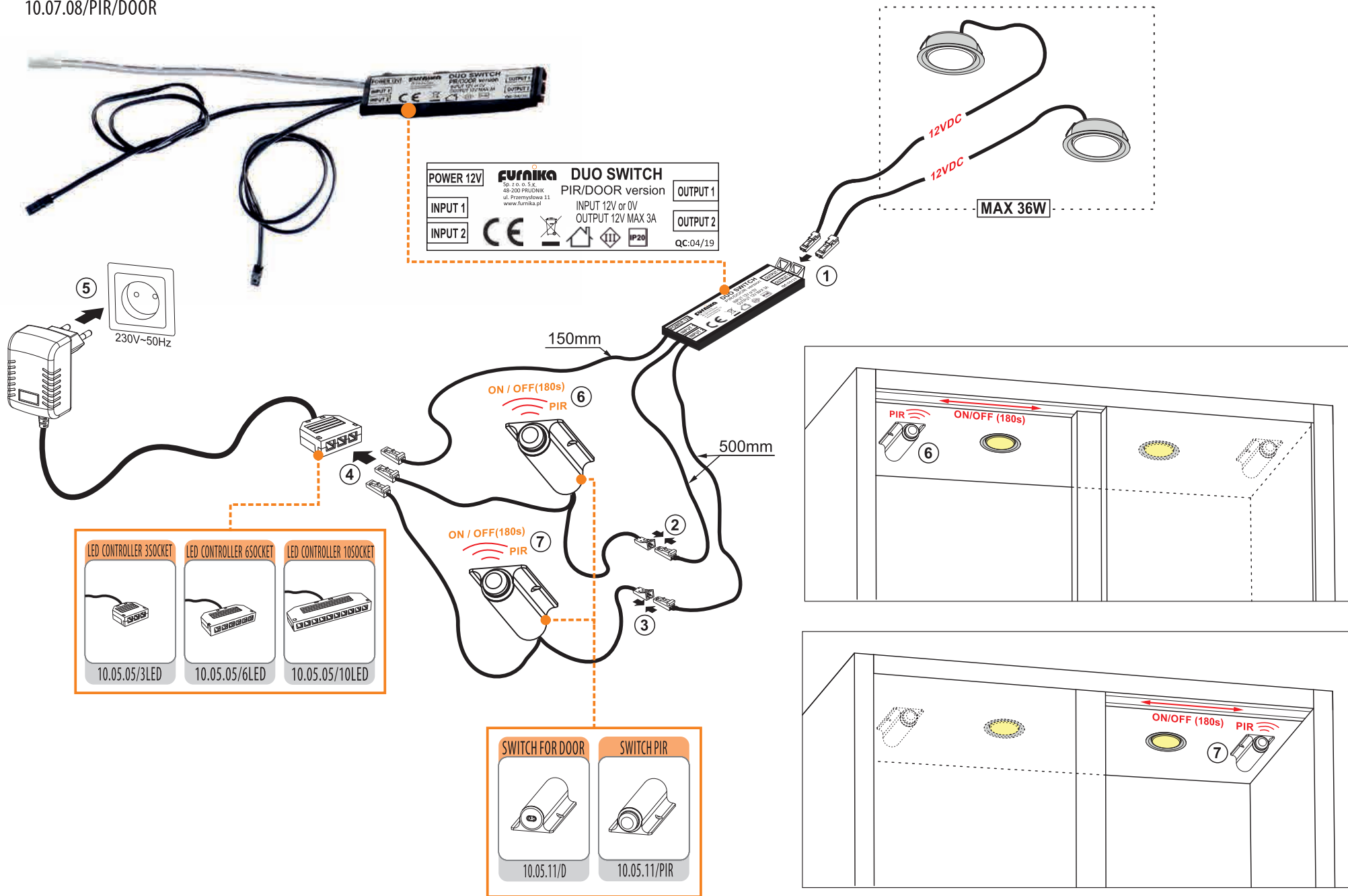

TOUCH SWITCH WITH DIMMER

Touch dimmable switch DIMMER /Berührungsschalter dimmer /выключатель с опцией стемнения



10.05.06/W

10.05.06/CH

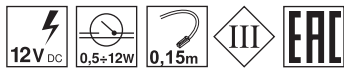
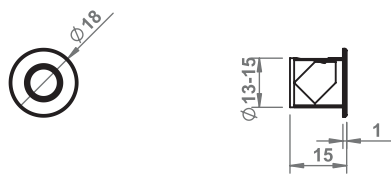
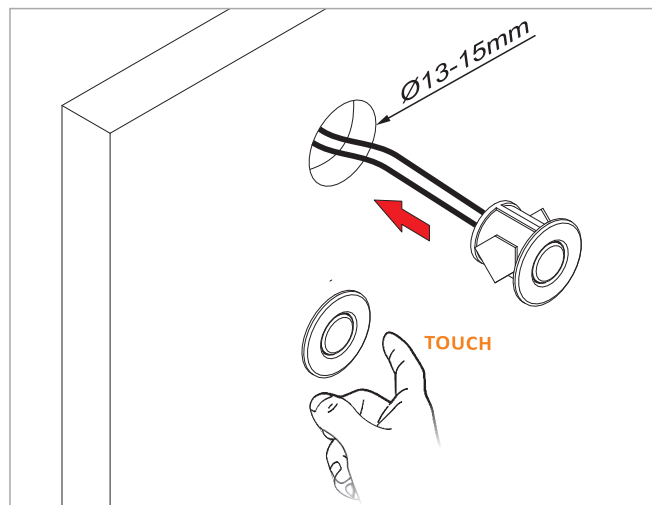

SWITCH WITH MOTION SENSOR

10.06.02 /switch with motion sensor/LED Sensorschalter/выключатель с датчиком движения

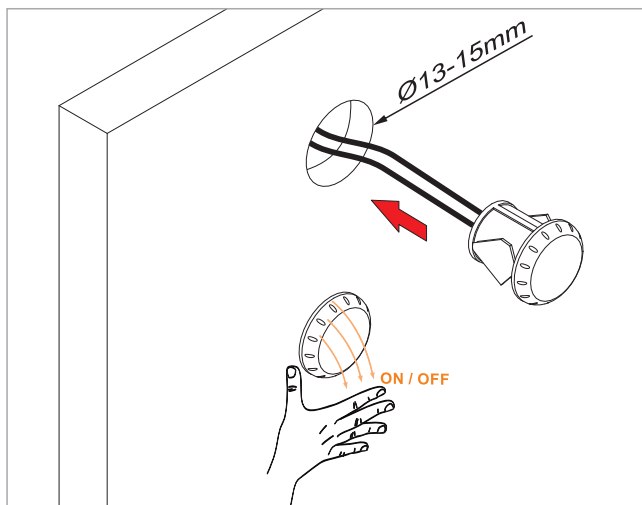

N battery box

10.06.04/N /Бокс питания на батареях

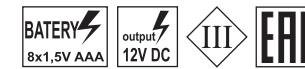
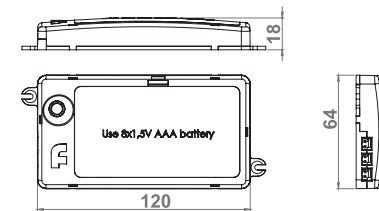
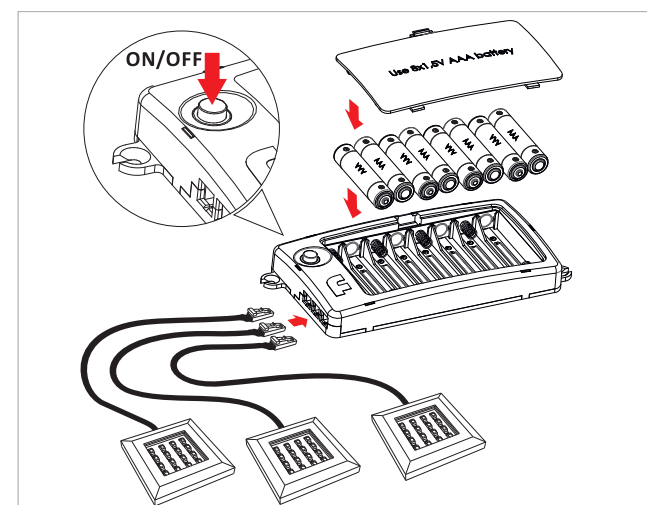

SWITCH F230 V1T

przykładowy schemat połączenia - SWITCH F230V1T / example connection diagram - SWITCH F230V1T / Beispiel Anschlussplan - SWITCH F230V1T

10.06.06/F230V

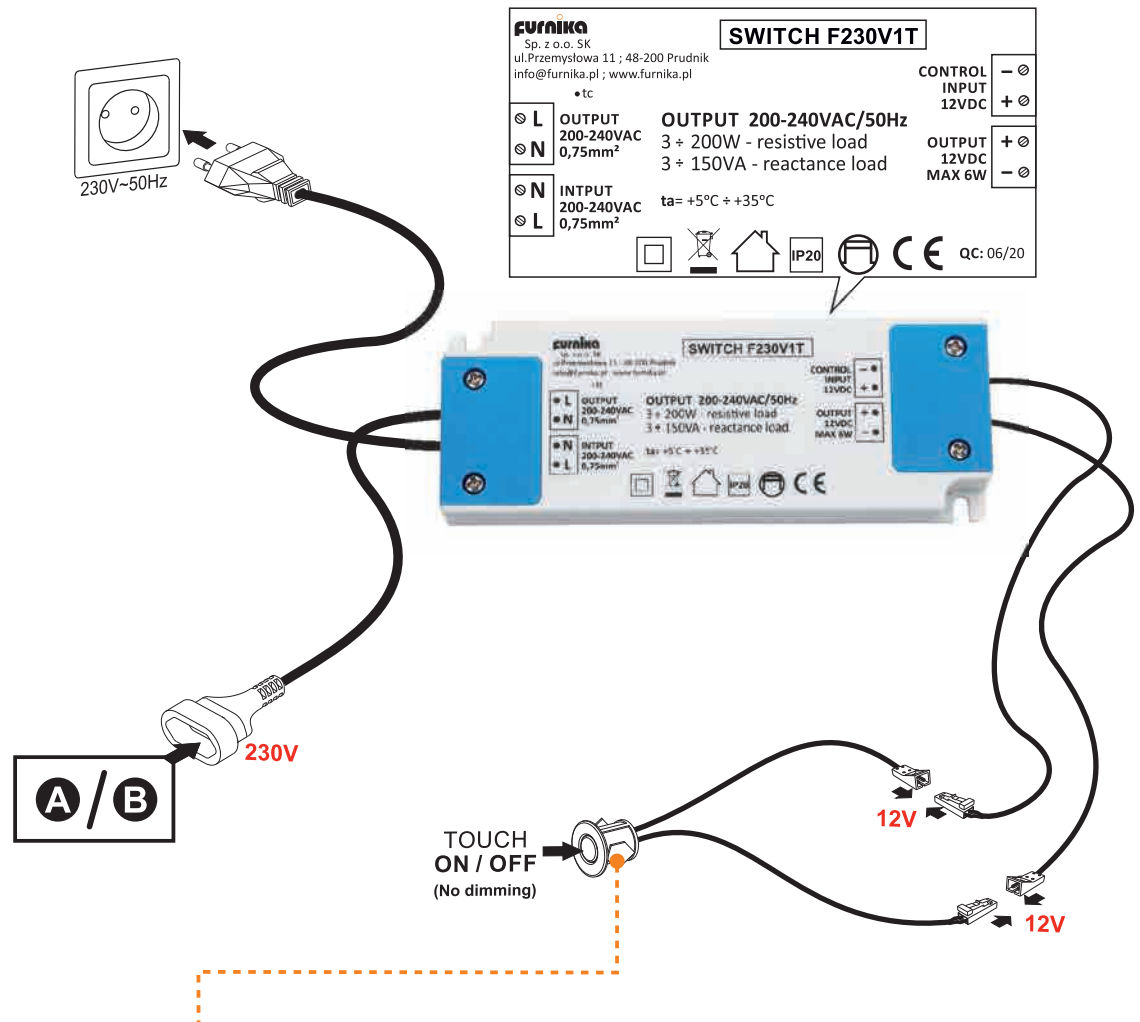
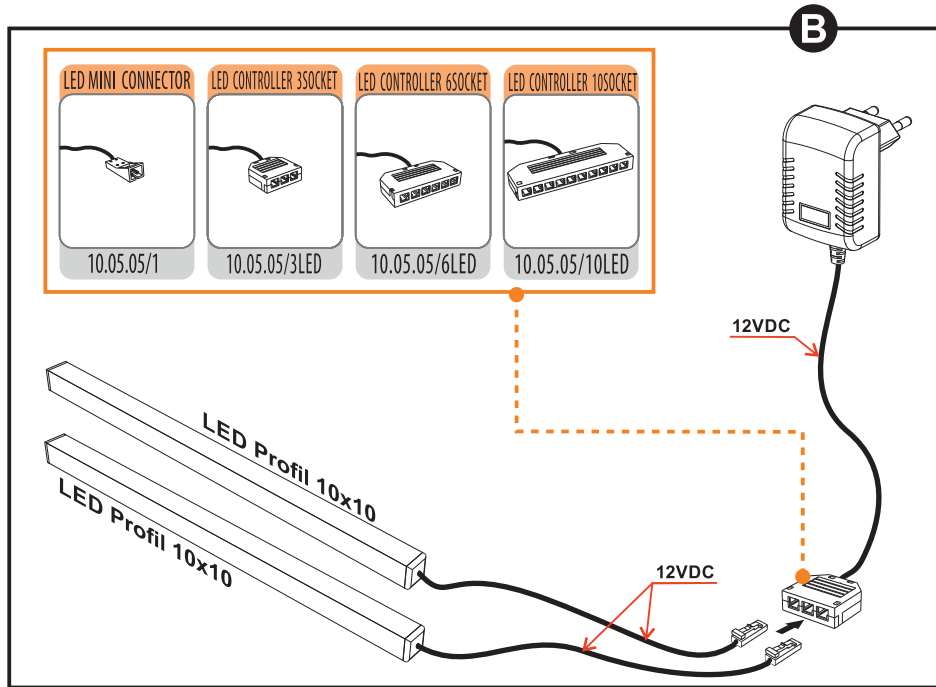
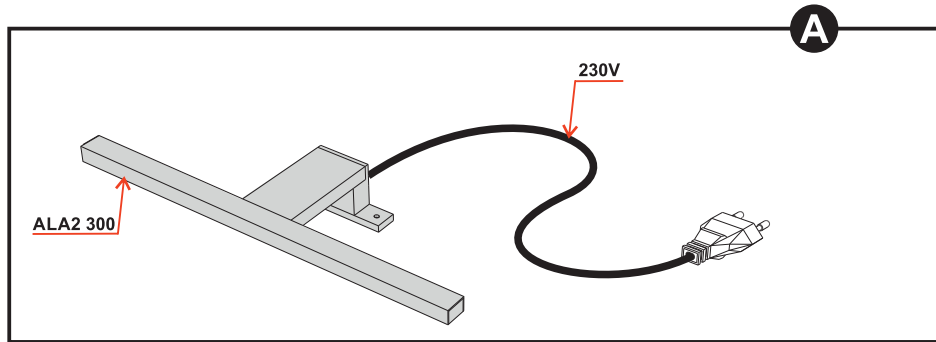

furnika
Sp. z o.o. SK
ul. Przemysłowa 11; 48-200 Prudnik
info@furnika.pl; www.furnika.pl

SWITCH F230V1T

• tc

⊗ L	OUTPUT 200-240VAC	OUTPUT 200-240VAC/50Hz	CONTROL INPUT 12VDC
⊗ N	0,75mm ²	3 ÷ 200W - resistive load	OUTPUT 12VDC
		3 ÷ 150VA - reactance load	MAX 6W
⊗ N	INPUT 200-240VAC	ta= +5°C + +35°C	
⊗ L	0,75mm ²		

QC: 06/20

TOUCH SWITCH No dimming 10.05.06/CH	SWITCH FI 22 10.05.14/12V	SWITCH FOR DOOR 10.05.11/D	SWITCH PIR 10.05.11/PIR	SWITCH FOR MOVEMENT 10.05.11/M.	NEW USB SWITCH 10.05.18.X	BED SWITCH M 10.05.16.X/M.	OMEGA SWITCH 10.01.26.X/W	SWITCH FOR CHIPBOARD 10.05.10	SWITCH 4LED FOR MIRROR No dimming 10.05.09/4LED	SWITCH FOR MIRROR No dimming 10.05.09
--	-------------------------------------	--------------------------------------	-----------------------------------	---	---	--------------------------------------	-------------------------------------	---	--	--

LED DRIVER / IP44



10.04.04/8W/IP23



10.04.04/8W/IP44

LED DRIVER / IP44



10.04.04/15W/IP23



10.04.04/15W/IP44

LED DRIVER / IP44



10.04.04/20W/IP23



10.04.04/20W/IP44

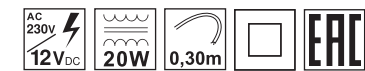
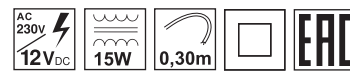
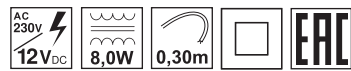
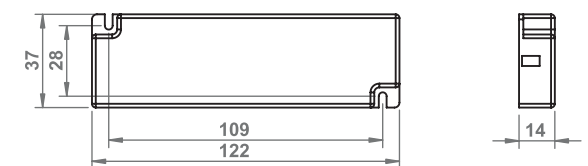
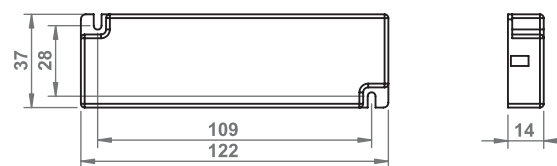
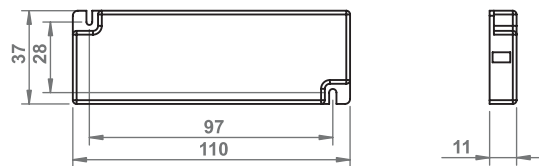
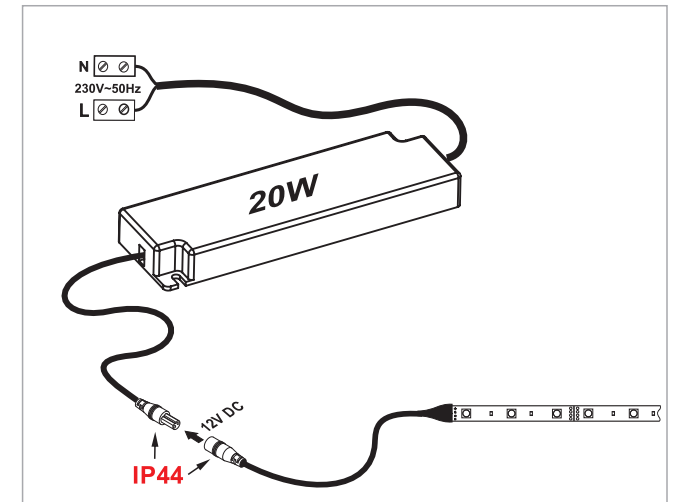
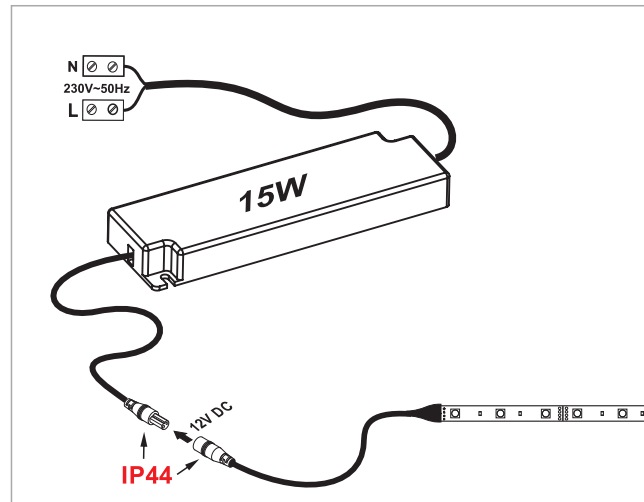
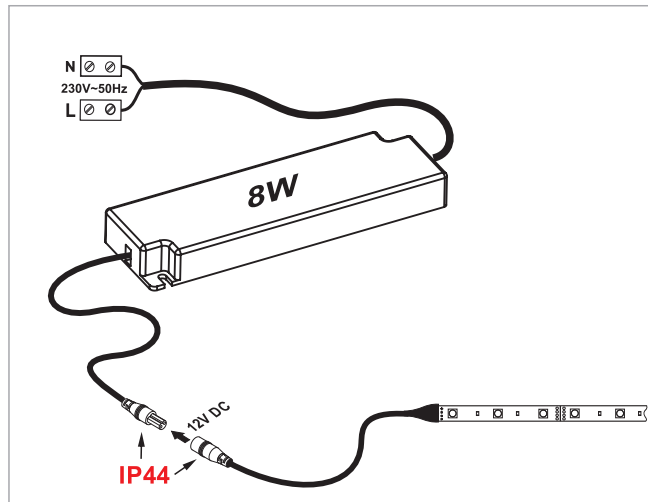

LED DRIVER 30W /IP44

10.04.04/30W/IP44

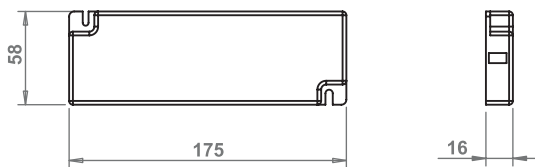
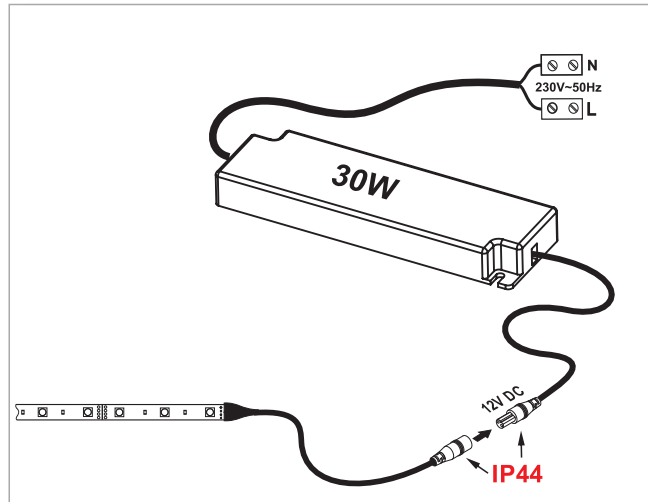

LED DRIVER 40W /IP44

10.04.04/40W/IP44

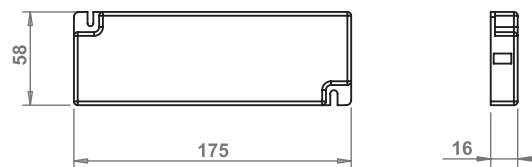
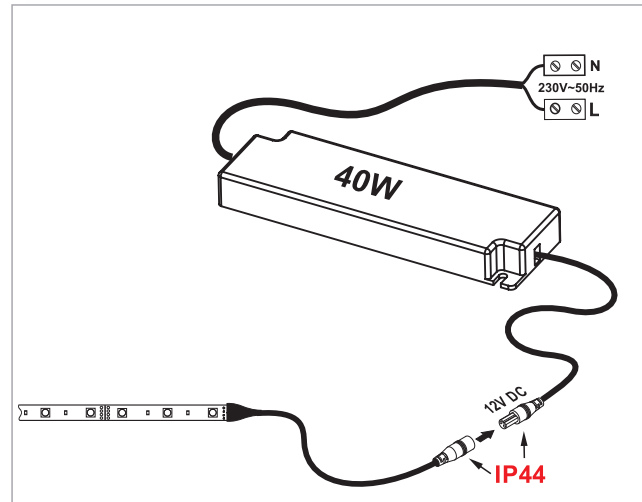

IP44 CONNECTOR SOCKETS

IP44 CONNECTOR 3 SOCKETS

10.05.05/3/IP44

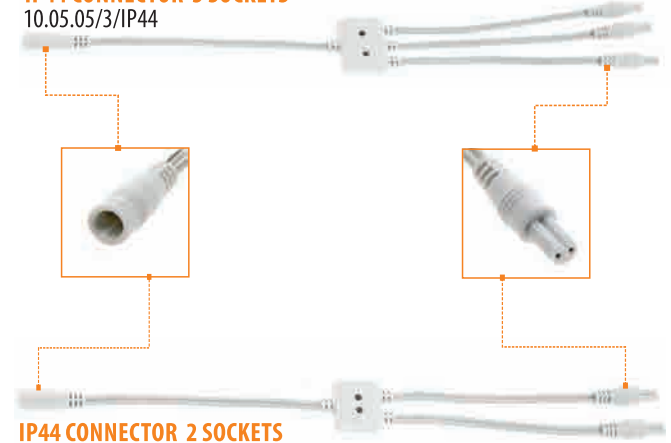

IP44 CONNECTOR 2 SOCKETS

10.05.05/2/IP44

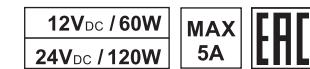
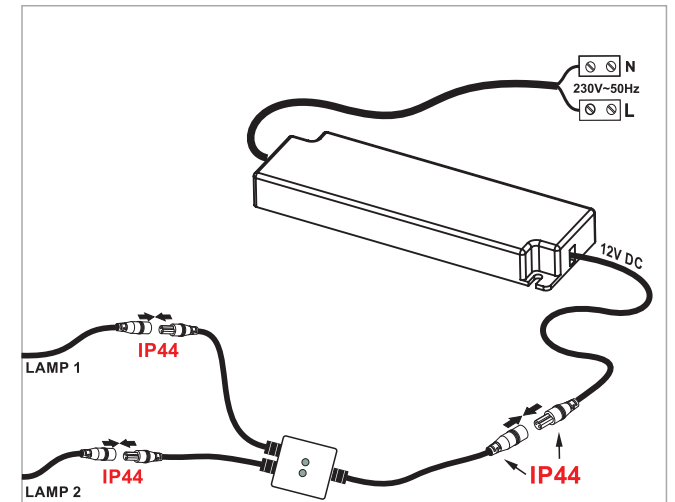

LED DRIVER 8W / 15W - IP20

/LED driver /LED Trafo /адаптер монтажный

10.04.03/8W



10.04.03/15W



LED DRIVER 30W / 40W - IP20

/LED driver /LED Trafo /адаптер монтажный

10.04.03/30W/IP20



10.04.03/40W/IP20



LED DRIVER 50W / 60W - IP20

/LED driver /LED Trafo /адаптер монтажный

10.04.03/50W/IP20



10.04.03/60W/IP20

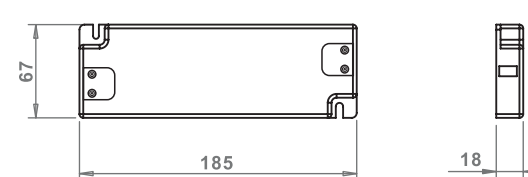
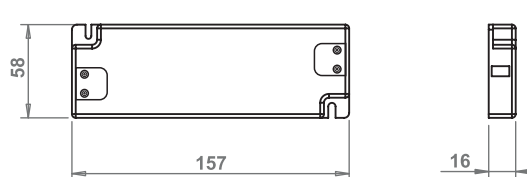
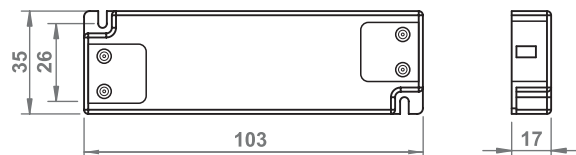
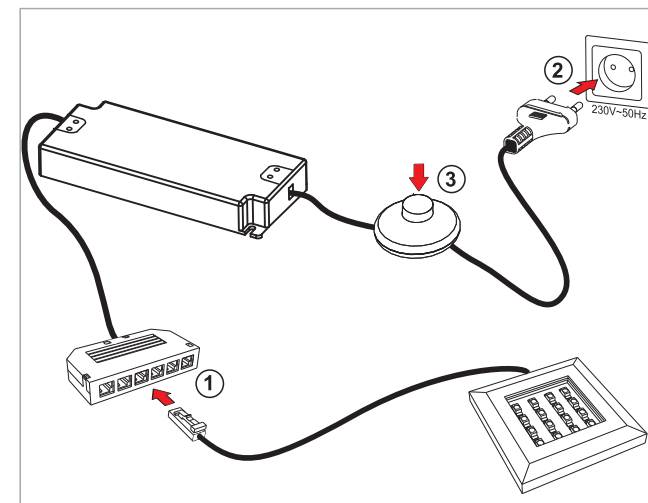
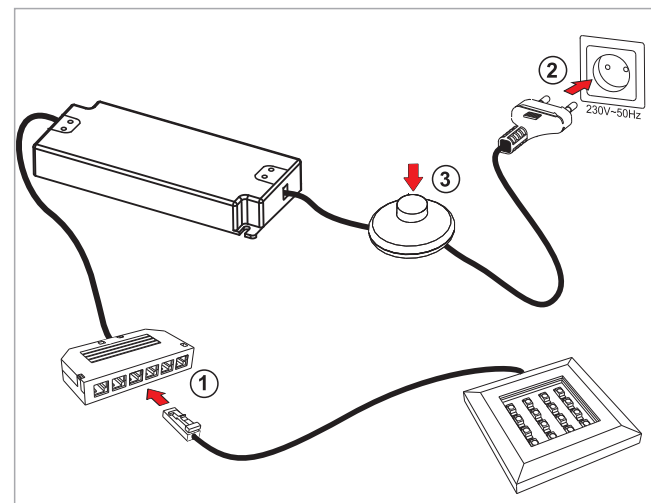
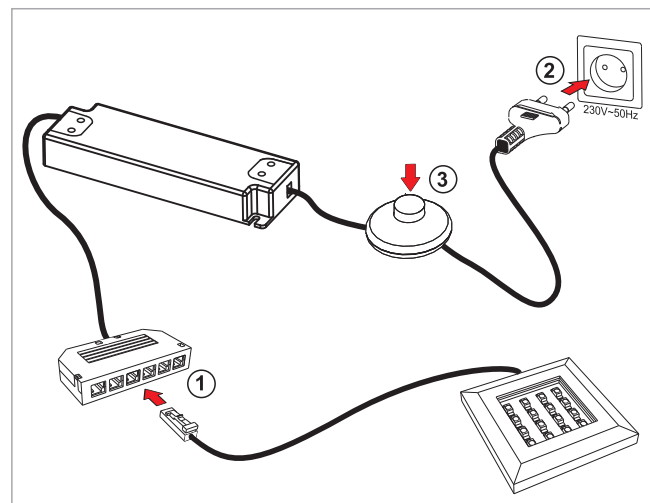

LED DRIVER EU / UK / USA

/LED driver /LED Трафо/адаптер монтажный

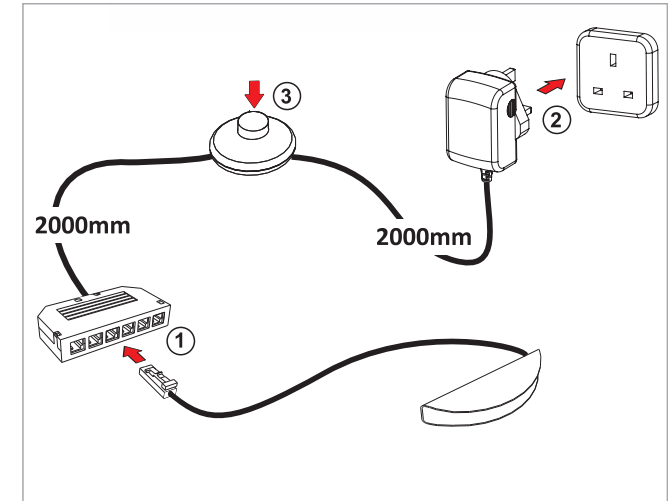
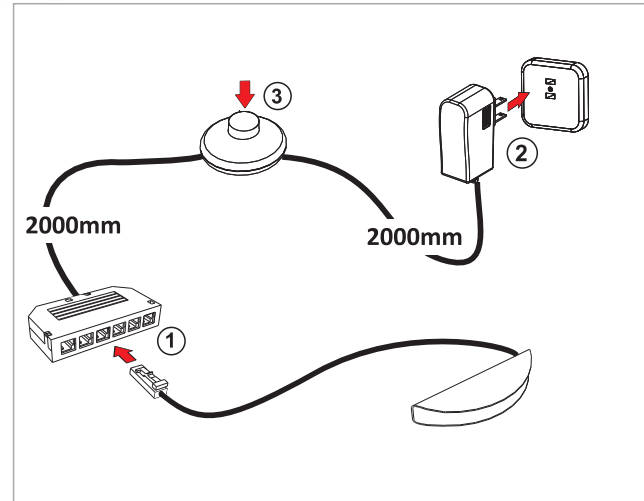
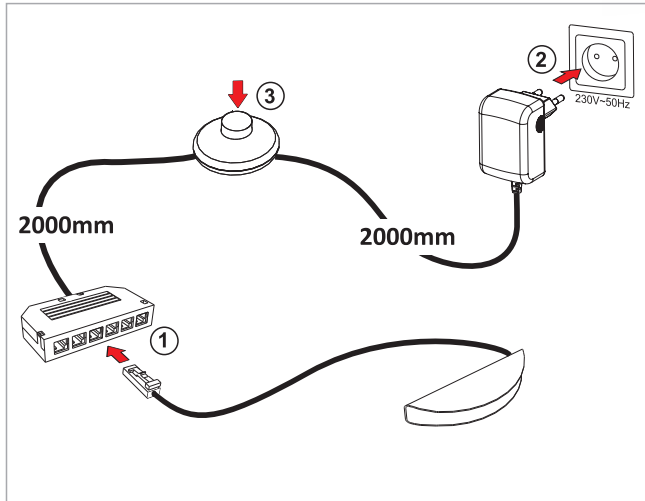

SOCKET WITH SWITCH / IP44

20.04.01/IP44 F /Socket with switch IP44 / Steckdose mit Schalter IP44/ гнездо с выключателем IP44



SOCKET WITH SWITCH

20.04.01 / F /Socket with switch / Steckdose mit Schalter / гнездо с выключателем



SOCKET WITH SWITCH / IP44

20.04.01/IP44 S



SOCKET WITH SWITCH

20.04.01

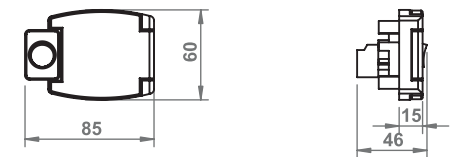
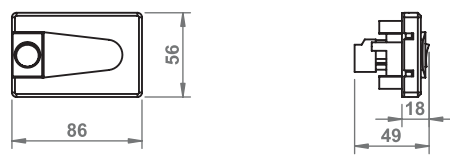
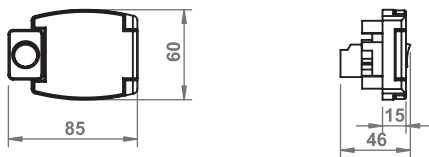
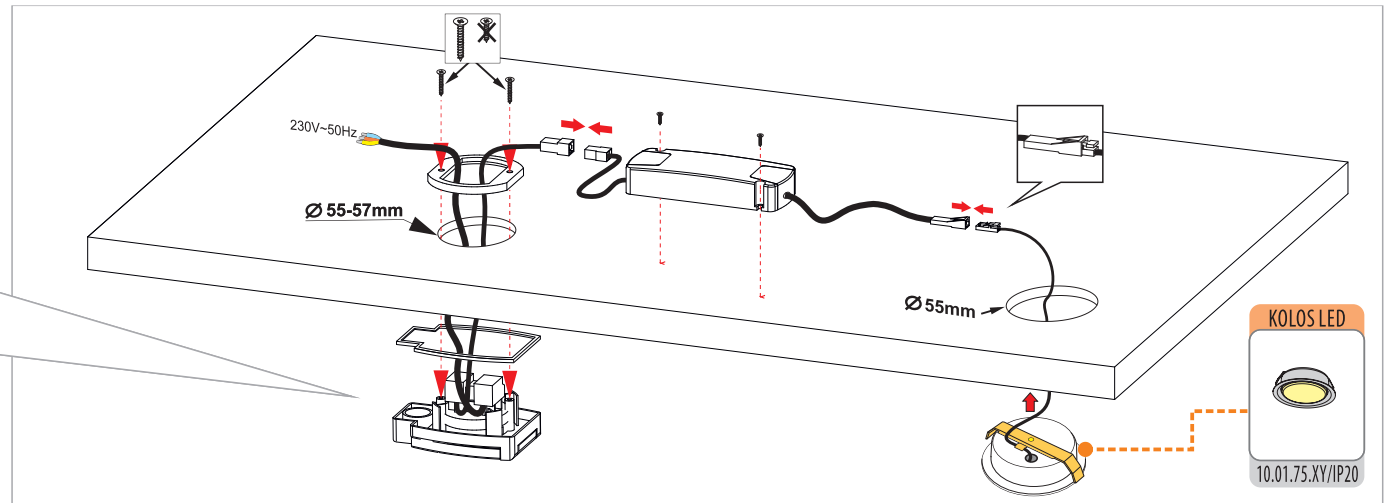
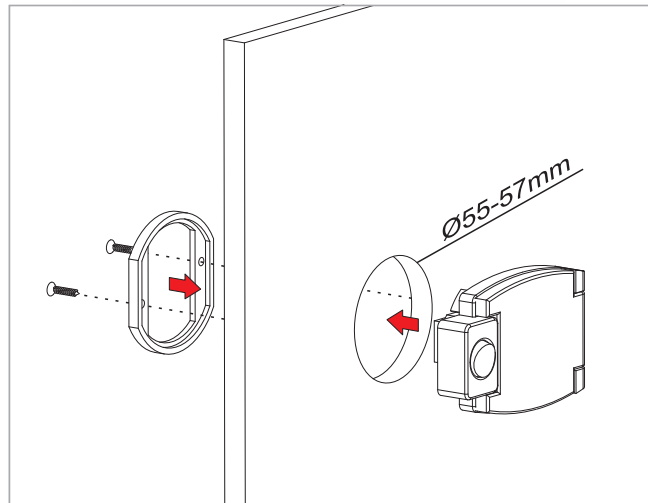
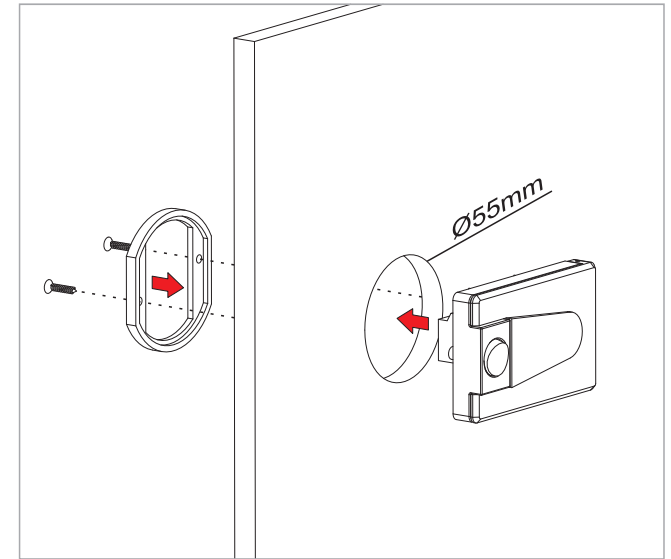

MINI BOX 12V

20.05.16.X/6W X: 4

20.05.16.X/15W X: 4

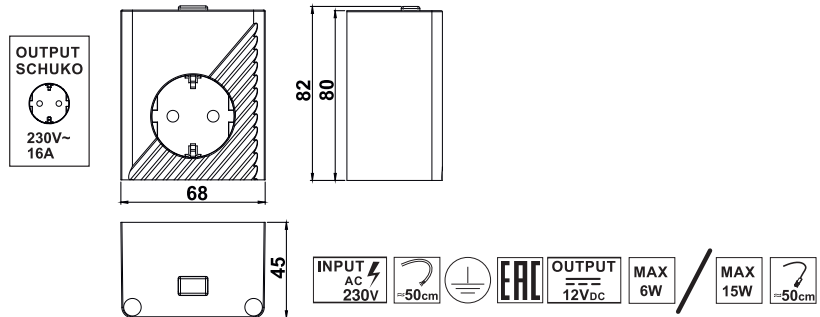
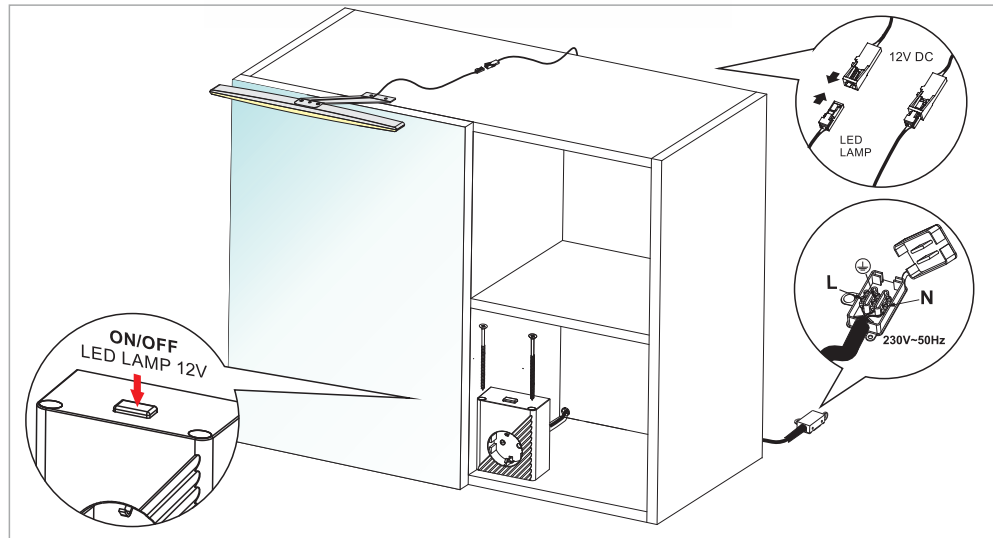
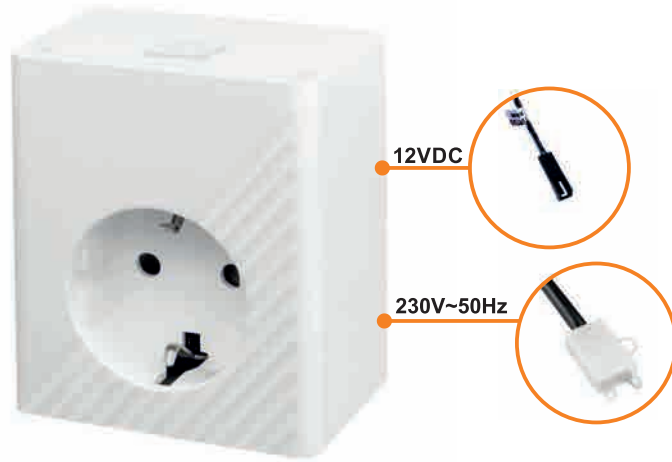

MINI BOX 230V

20.05.17.X/230V X: 4

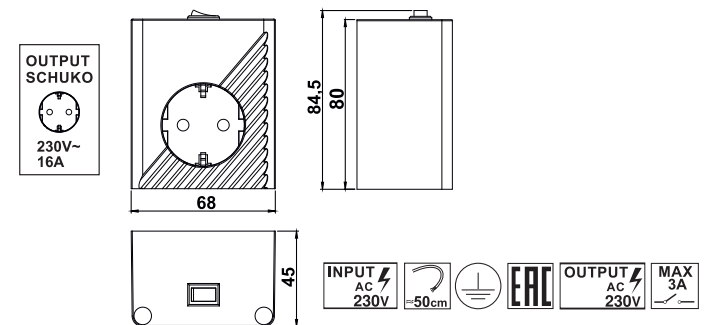
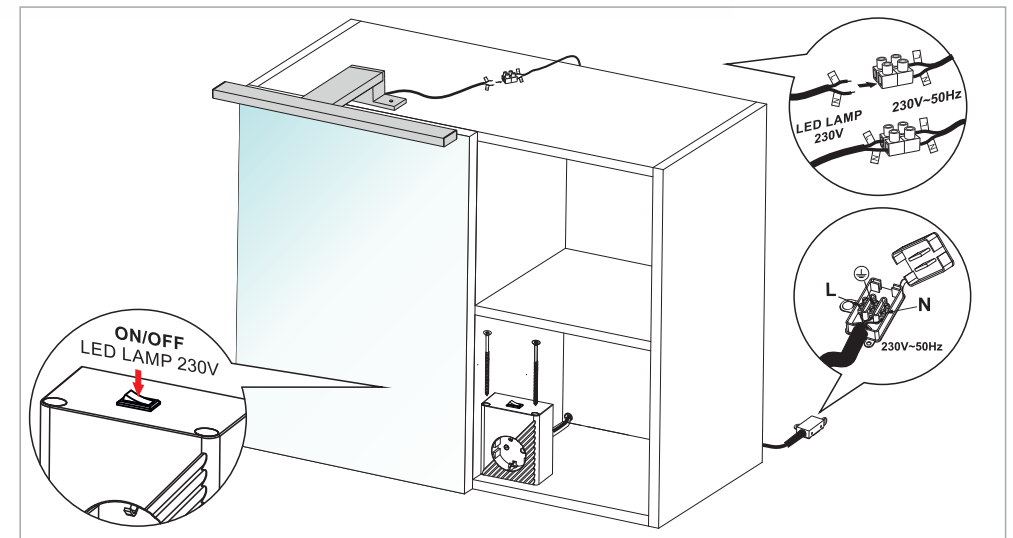
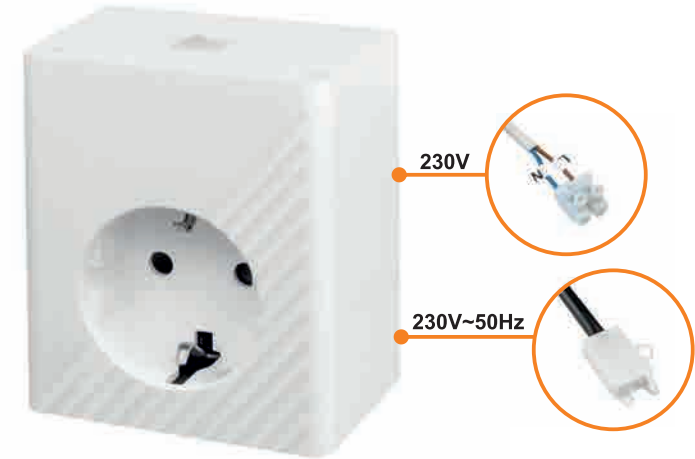

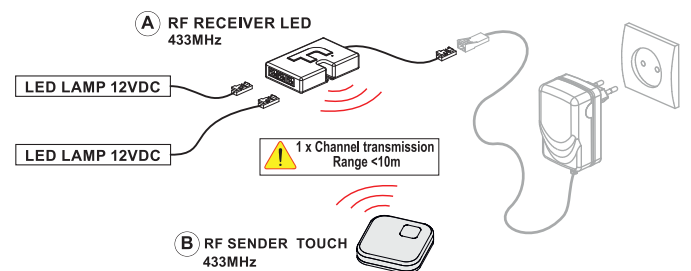
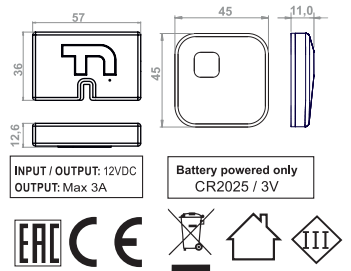
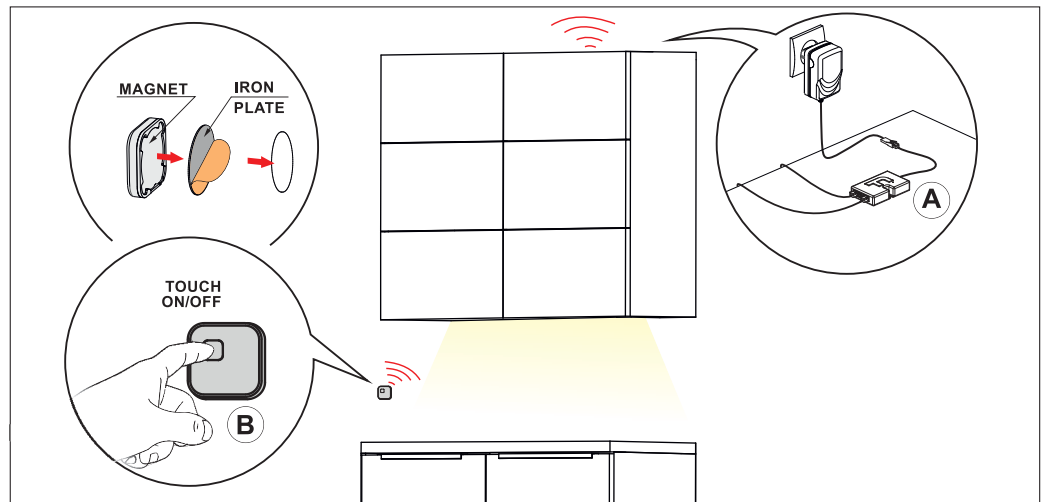
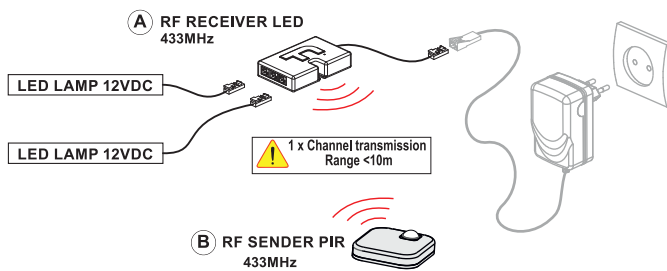
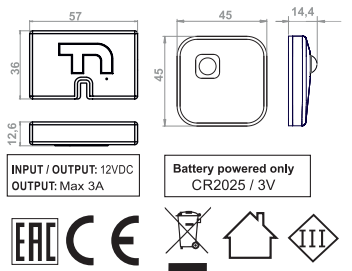
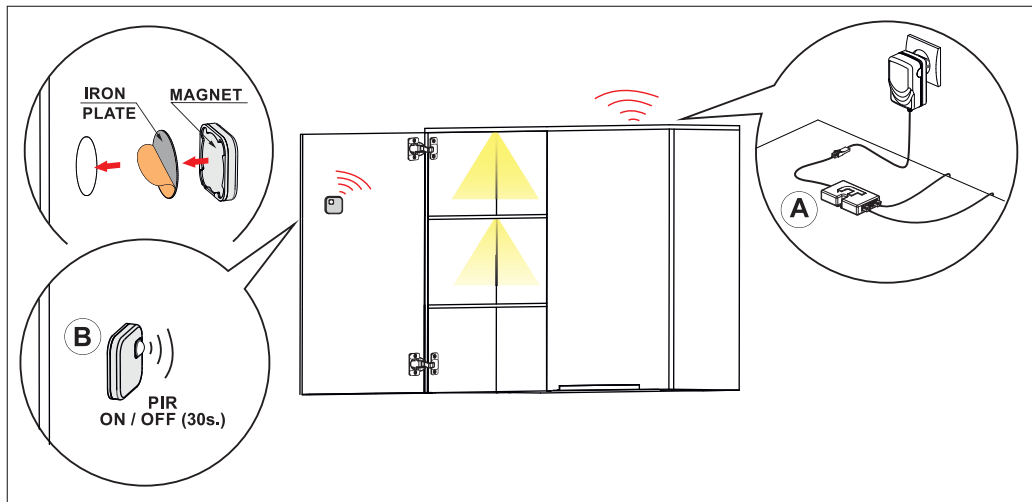

TAPE ARGB

10.05.53/ARGB



RF CONTROLLER RGBWS for TAPE ARGB

10.05.53/RGBWS

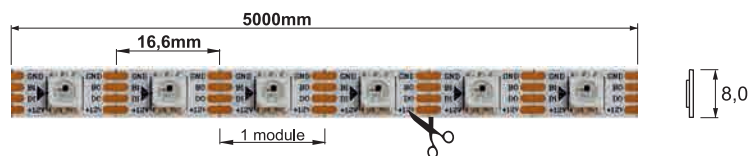
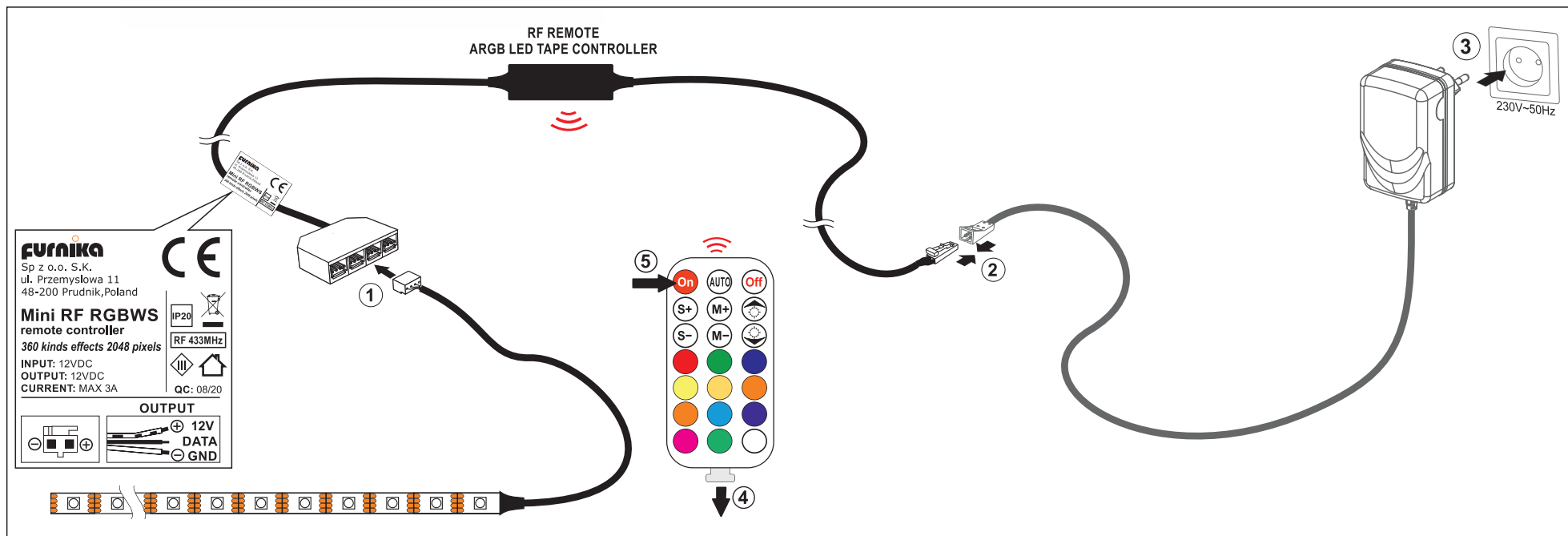

12V _{DC}	TAPE ARGB	TAPE ARGB		
	7,5 W/m	60 module/m		

RGB LED CONTROLLER IR 2xCHANNEL

10.04.05/RGB2K RGB Controller IR 2K / Trafo mit Steuerung / Контролер LED 2- канальный

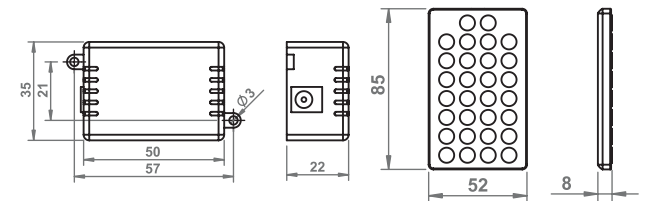
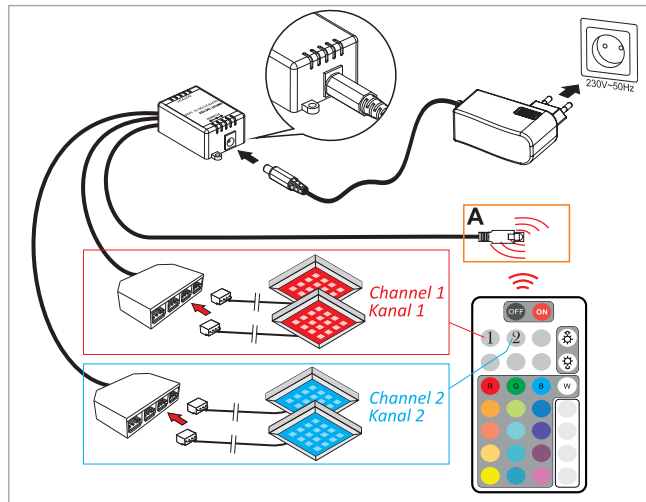
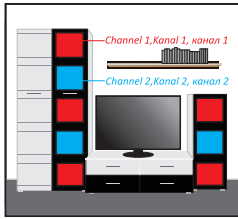

12V DC MAX 2x1A EAC

RGB LED CONTROLLER IR

10.04.05 /RGB LED controller IR/Led Stecker Trafo mit Steuerung IR/ RGB LED Контролер IR

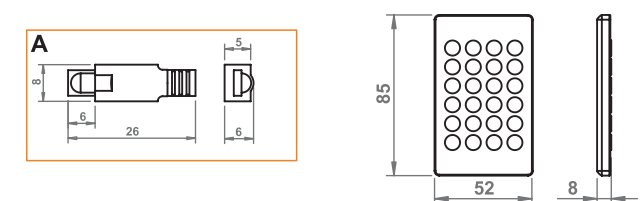
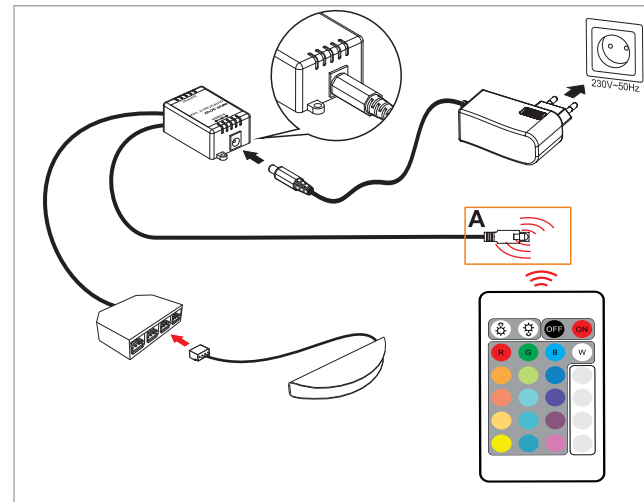

12V DC MAX 3x2A EAC

MINI RGB LED CONTROLLER

10.04.06 /MINI RGB LED controller /MINI Led Stecker Trafo mit Steuerung / MINI RGB LED Контролер

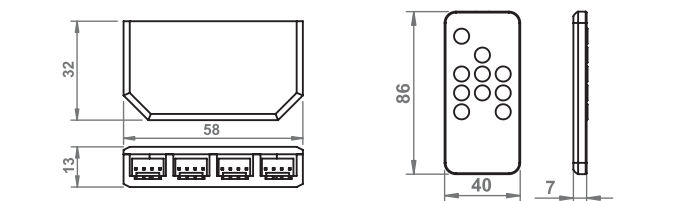
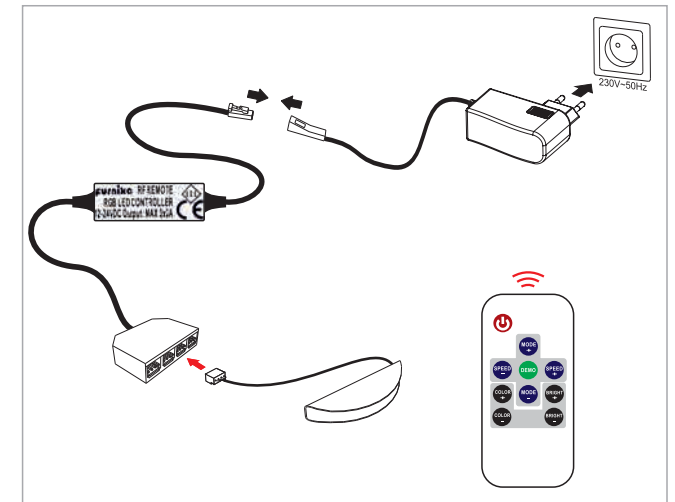

12V DC MAX 3x2A EAC

RF REMOTE DIMMER SWITCH - RF101

10.04.08

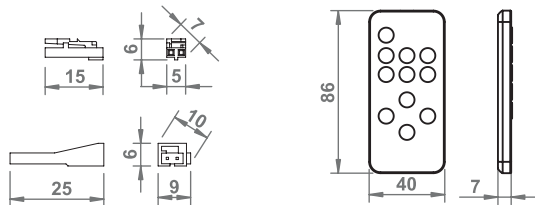
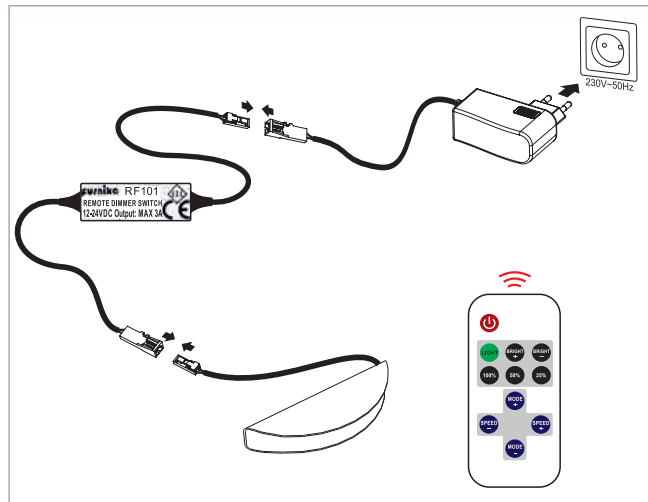

12V _{DC} / 36W	MAX 3A	EAC
24V _{DC} / 72W		

PANEL RGB

10.04.07

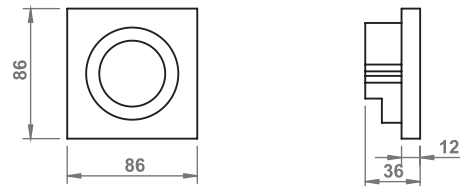
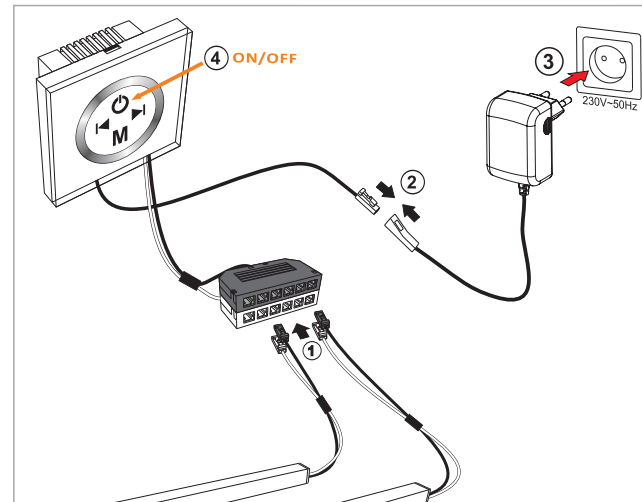

12V _{DC} / 48W/CH	MAX 4A/CH	EAC
24V _{DC} / 96W/CH		

LED DRIVER+DIMMER SWITCH

10.07.05 / Zasilacz sieciowy LED+Ściemniacz/LED Trafo + LED Funk Dimmer / адаптер сетевой (система управления питанием)+выключатель с опцией стемнения

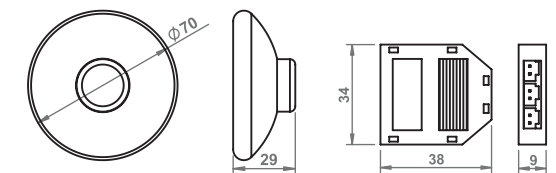
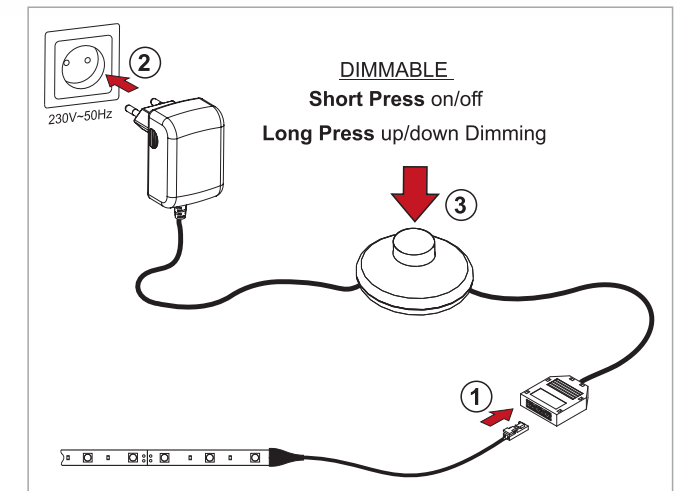

12V _{DC} / 12W	MAX 1A	4m	III	EAC
-------------------------	--------	----	-----	-----

WATCH FOR MIRROR

10.05.12.XY X: 8 ● Y: 1 ○ 3 ● /mirror watch/Spiegeluhr/Часы для зеркала



widok dzien/miesiac
view day / month //
anzuzeigen Tag / Monat //
смотреть день / месяц //

widok rok
year view //
Jahr Ansicht //
Просмотр года //

widok godzina
view hours //
anzuzeigen Stunden //
просмотреть часов //

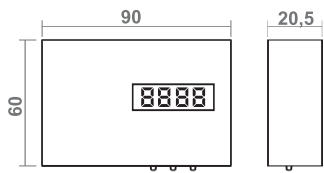
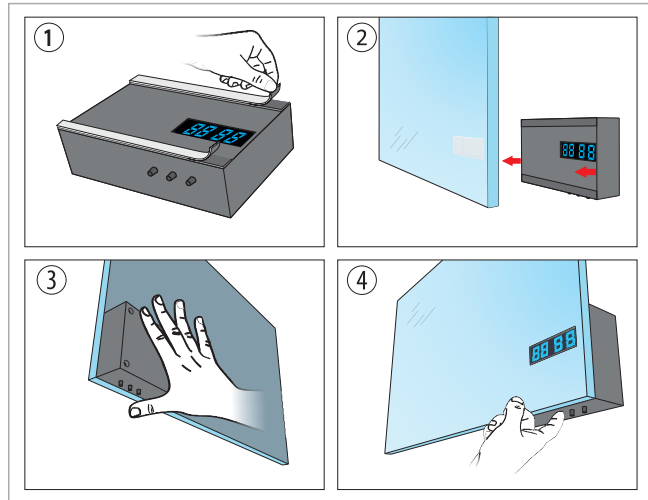

WATCH FOR MIRROR V2

10.01.103.XY X: 8 ● Y: 1 ○ 3 ● /mirror watch/Spiegeluhr/Часы для зеркала

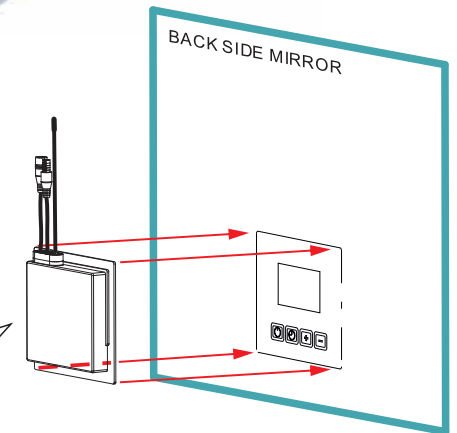
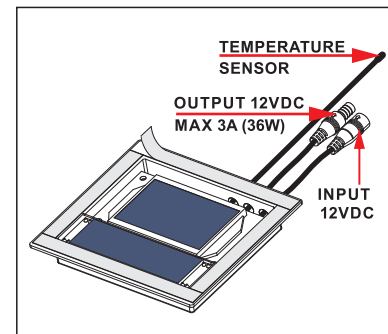
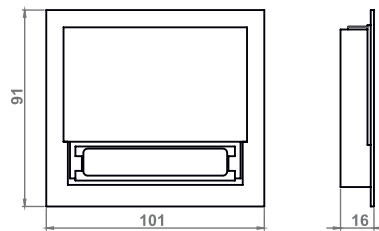

KOLOS LED / IP44

10.01.75.XY X: 1 ● 2 ○ Y: 1 ○ 8 ○



ROUND

10.01.17.XY X: 1 ● 2 ○ 3 ● Y: 1 ○ 2 ○



ROUND DY

10.01.17.XY/D X: 1 ● 2 ○ 3 ● Y: 1 ○ 2 ○

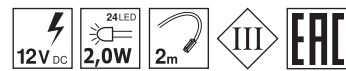
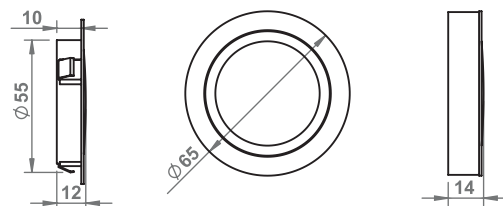
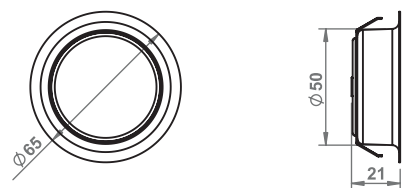
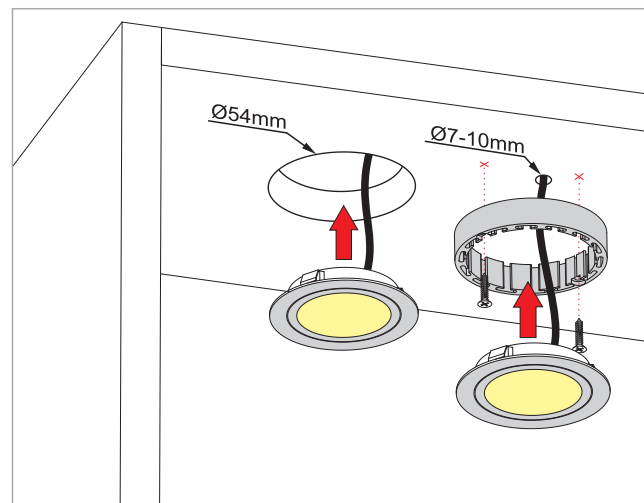
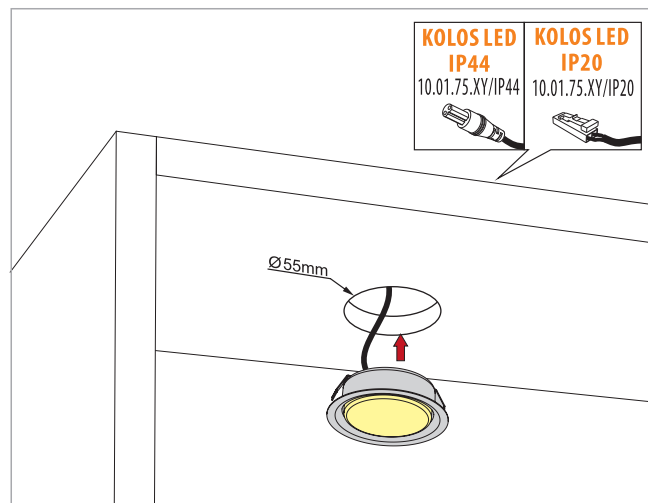

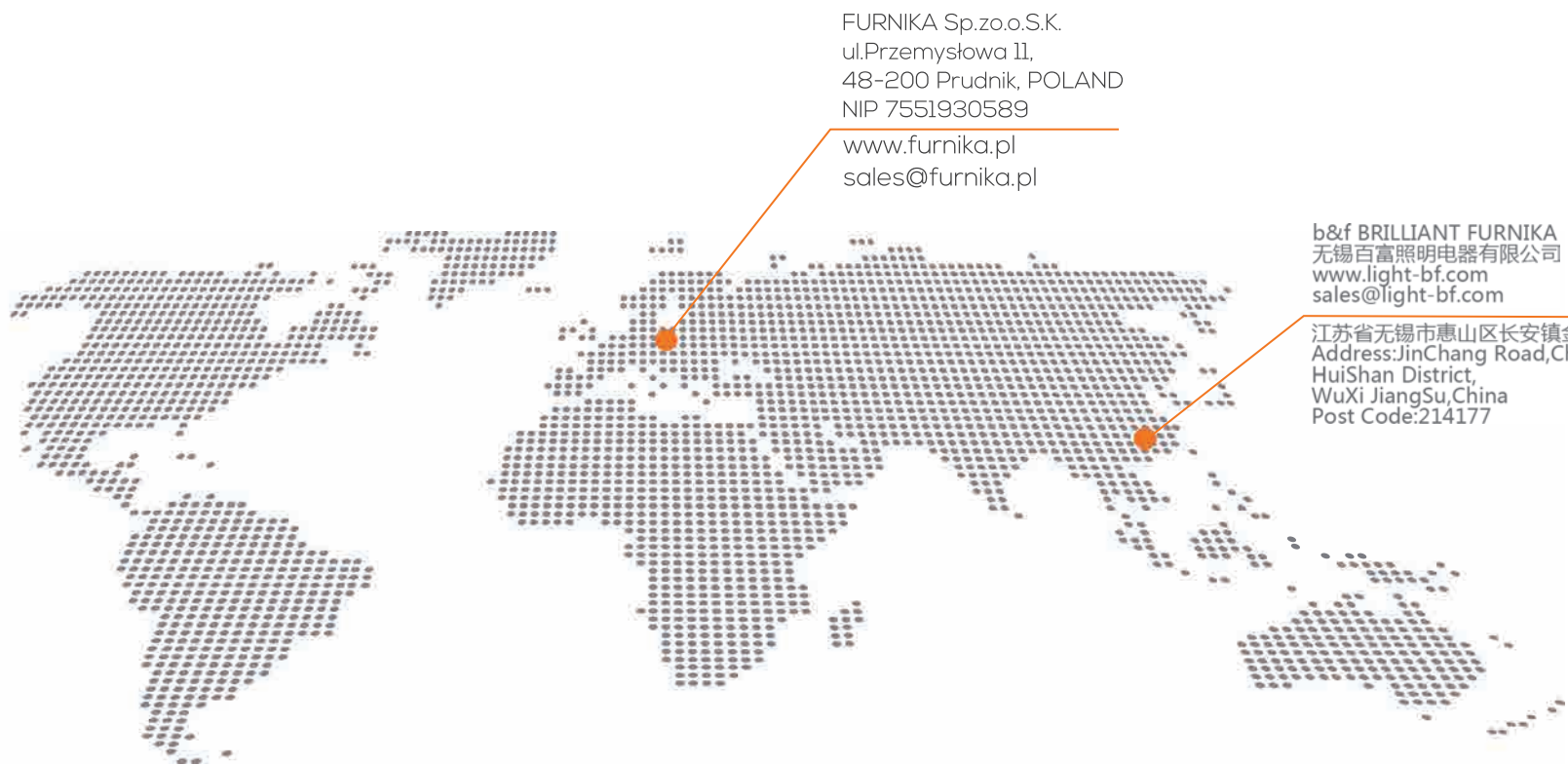

FURNIKA Sp.zo.o.S.K.
ul.Przemysłowa 11,
48-200 Prudnik, POLAND
NIP 7551930589

www.furnika.pl
sales@furnika.pl

b&f BRILLIANT FURNIKA
无锡百富照明电器有限公司
www.light-bf.com
sales@light-bf.com

江苏省无锡市惠山区长安镇金长路
Address:JinChang Road,Chang An ,
HuiShan District,
WuXi JiangSu,China
Post Code:214177